



LUCASMETAL WORKS®

ASSEMBLY & SAFETY MANUAL



**Lucas Metal Works®
396281 West 3000 Road
Ochelata, OK 74051**

**TOLL FREE: 918-535-2726
email: info@lucasmetalworks.com
web: www.lucasmetalworks.com**

BUILT TO LAST

TABLE OF CONTENTS

Introduction.....	3
Foundation	4 - 5
Foundation Layout.....	4
Setting Anchor Bolts.....	5
Unloading Materials.....	6 - 11
Shipment Arrival Time	6
Shipment Inspection and Receiving.....	6
General Hoisting Information	10
Structural Framing Primer	10
Wall & Roof Panels	11
Assemble Structural Steel	12 - 20
General Information.....	12
Recommended Tools	12
Erect Sidewall Components.....	13
Install Roof Components and Cable Bracing.....	14
Plumb, Square and Secure the Rigid Frames and Bays	15
Erect Bearing Endwall Components	17
Plumb, Square and Secure the Bearing Frame Endwalls	18
Install Framed Openings	18
Install Base-Angle and Rake-Angle.....	20
Final Frame Bolt Inspection.....	20
Support Girts for Panel Installation	20
Install Wall Insulation, Panels, Corner Trim, and Eave Trim/Gutter Counter Flashing	21 - 45
Panel Descriptions	21
Worksite Preparation	21
Pre-drill Sidewall Panels.....	22
Sidewall Insulation and Panel Installation	27
Pre-drill Endwall Panels	34
Endwall Insulation and Panel Installation.....	38
Corner Trim Installation	44
Eave Trim/Gutter Counter Flashing Installation.....	45
Install Roof Insulation, Panels, and Ridge Caps.....	47 - 62
Pre-drill Roof Panels.....	47
Safety Precautions for Roof Panel Installation	49
Roof Insulation and Panel Installation	49
Roof Panel Installation Grid	51
Install Gutters, Downspouts, Rake Trim, and Peak Boxes	63 - 71
Gutter and Downspout Installation	63
Rake Trim Installation	67
Peak Box Installation	71
Install SKYLIGHT PANEL CLUSTER.....	72 - 75

INTRODUCTION

Lucas Metal Works® produces high quality, pre-engineered metal buildings. For your new building to yield optimum integrity and durability, proper assembly is required. This manual provides detailed and general assembly instructions. The Lucas Metal Works® Assembly and Safety Manual is intended to be an aid for your Pre-engineered Drawings, which dictate specific building parts and construction details. Lucas Metal Works® assumes that only an experienced knowledgeable erector with trained crews and proper equipment will perform the assembly.

The manufacturer is committed to producing quality-building components that can be safely assembled. It is a top priority to always utilize proven and safe procedures while employing accident prevention methods. The safety practices at the job site are beyond the control of the manufacturer(s). To help ensure worker safety, adhere to Local, State and Federal safety and health standards. Make certain all employees know the safest and most productive way of erecting building. Take careful note of any overhead electric lines or other utilities to avoid hazards and damage.

Post EMERGENCY telephone numbers. Everyone present should know location of first aid stations and emergency procedures at the site.

The manufacturer intends that this manual be interpreted and administered with sound judgment consistent with good safety practices.

It is understood that the manufacturer of the metal building and/or components is not engaged in the erection/assembly of its product(s). The provided erection suggestions are intended only as a guide as to how the component should be assembled. The expertise and skills of the erection crew, as well as the available equipment will determine the customer's satisfaction and quality of the completed building.

It is important to research and investigate any vendor or contractor for comparing price, quality, and time of completion as related to the assembly of your new building. The manufacturer (s) will answer any questions that may arise but will not physically be involved in the assembly process. Any agreement or representation between dealer or contractor and buyer concerning delivery, construction, modifications or other items are between the parties thereto.

The manufacturer(s) is not liable for the quality of erection, erection safety procedures, poor foundation design, or assembly, site selection and preparation, including soil drainage testing or the negligence of the other parties. Due to variations in load and zoning requirement, it is the customer's responsibility to make certain that the building conforms to all codes. At the additional cost, Lucas Metal Works® can engineer and supply building components to meet special requirements.

Moderate cutting and reaming or correcting minor misfits are considered part of the assembly process. Any fabrication errors preventing proper assembly or the fitting of parts by moderate use of reaming, chipping, or cutting should be reported to the manufacturer(s), so that he may either correct the error or approve the method of correction to be used.

To ensure against any loss or damage, it is the customer's responsibility to purchase and maintain liability insurance for complete assembly process and thereafter.

To the best of our knowledge, this information is accurate. However, Lucas Metal Works® disclaims any responsibility for damages that may result from the use of this manual since the actual erection and assembly operations and conditions are beyond our control.

Prior to construction, it is recommended that you read the erection manual and thoroughly study the "Pre-Engineered Drawings". Understanding the assembly process allows the erector to properly plan the assembly and help to avoid unnecessary delays. It is the customer's responsibility to be familiar with all laws and regulations that govern permitting, labor and employment, safety, materials handling and disposal, and any other issues which apply. A copy of this manual may be obtained at a nominal cost.

FOUNDATION LAYOUT

Regardless of the type of foundation that is used and its specific configuration, the foundation outline should be carefully and accurately laid out before any excavation is made. Whenever possible, a transit or similar means should be used to layout the foundation perimeter. This will ensure accurate placement of corner measures and in turn, ensure a square foundation.

1. Confirm the foundation is square and level. (Figure 01)

- 1.1 Measure diagonally to the farthest points of the foundation frame/string-line.
- 1.2 Adjust the frame/string-line as necessary until the two diagonal dimensions are equal.
- 1.3 If the diagonal lengths are equal, the framing is square.
- 1.4 Ensure the foundation is level.

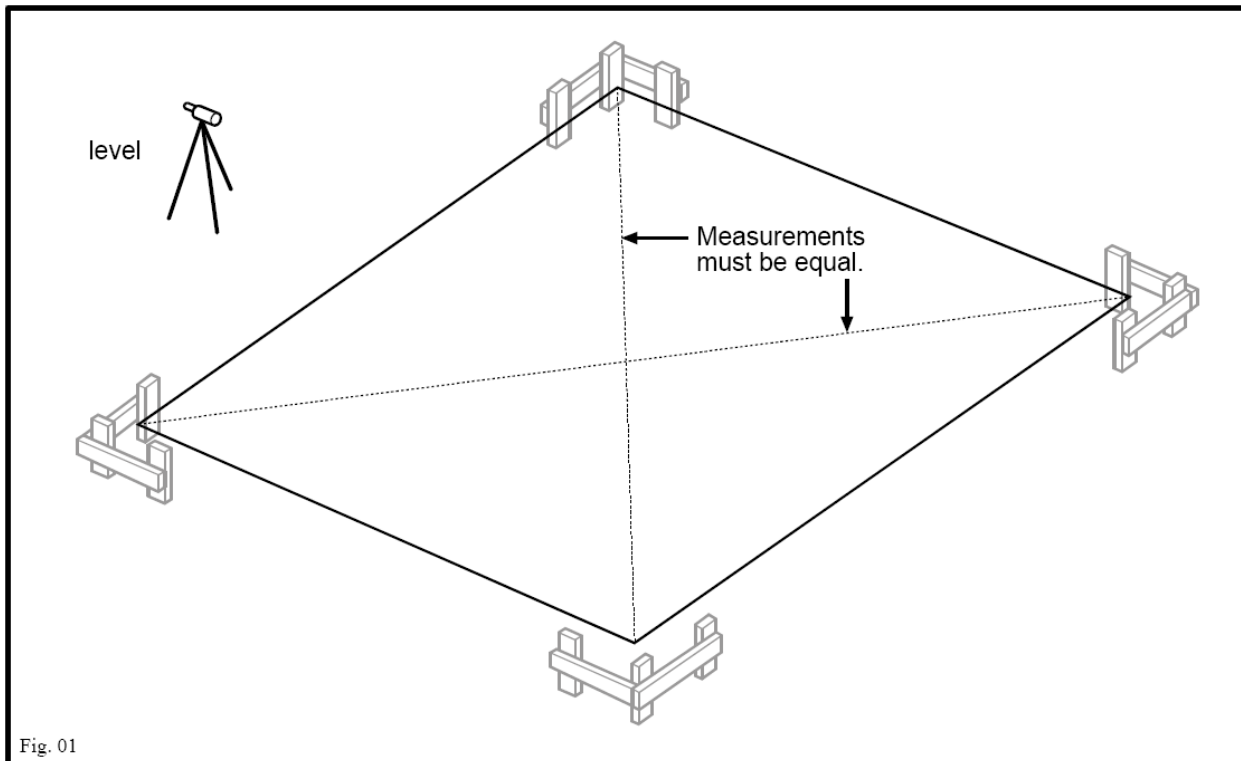

Fig. 01

SETTING ANCHOR BOLTS

Precaution: To reduce the risk of anchor bolt(s) pulling loose, do not erect any building components on “green” concrete. Concrete that has not cured properly damaged by erection equipment or building component affects. Normal Portland cement concrete should cure at least seven days, and high early strength concrete at least three days before the structural columns are erected.

Precaution: Due to tight tolerances in which your building was manufactured, it is extremely important that all anchor bolts are accurately placed ($\pm 1/16''$) in accordance with the provided anchor bolt plan.

2. Prior to pouring the concrete, study carefully the following general notes describing size, type and position of anchor bolts. (Figure 02)

2.1. Use ASTM A-307 anchor bolts or equivalent containing a thread length of at least 2-1/2”.

2.2. Anchor bolts should project at least 2” above the concrete surface. (Refer to Anchor Bolt setting plan)

2.3. Prior to pouring the concrete use duct tape to wrap and protect the bolt threads.

Tip: All anchor bolts should be held in place with a template or similar means in order to maintain a plumb setting during the pouring of the concrete. Refer to the anchor bolt plan dimensions a then make the necessary quantity of templates out of plywood or equivalent. All templates should be prepared in advance so they can be quickly nailed in place. Drill air relief holes in the template to allow trapped air to escape. When floating concrete, vibrate until wet concrete seeps through the top of air relief holes.

Important: A final inspection of all foundation requirements should be conducted prior to pouring concrete. MAKE SURE ALL FOUNDATION REQUIREMENTS ARE PRESENT AND ACCURATE!!!!

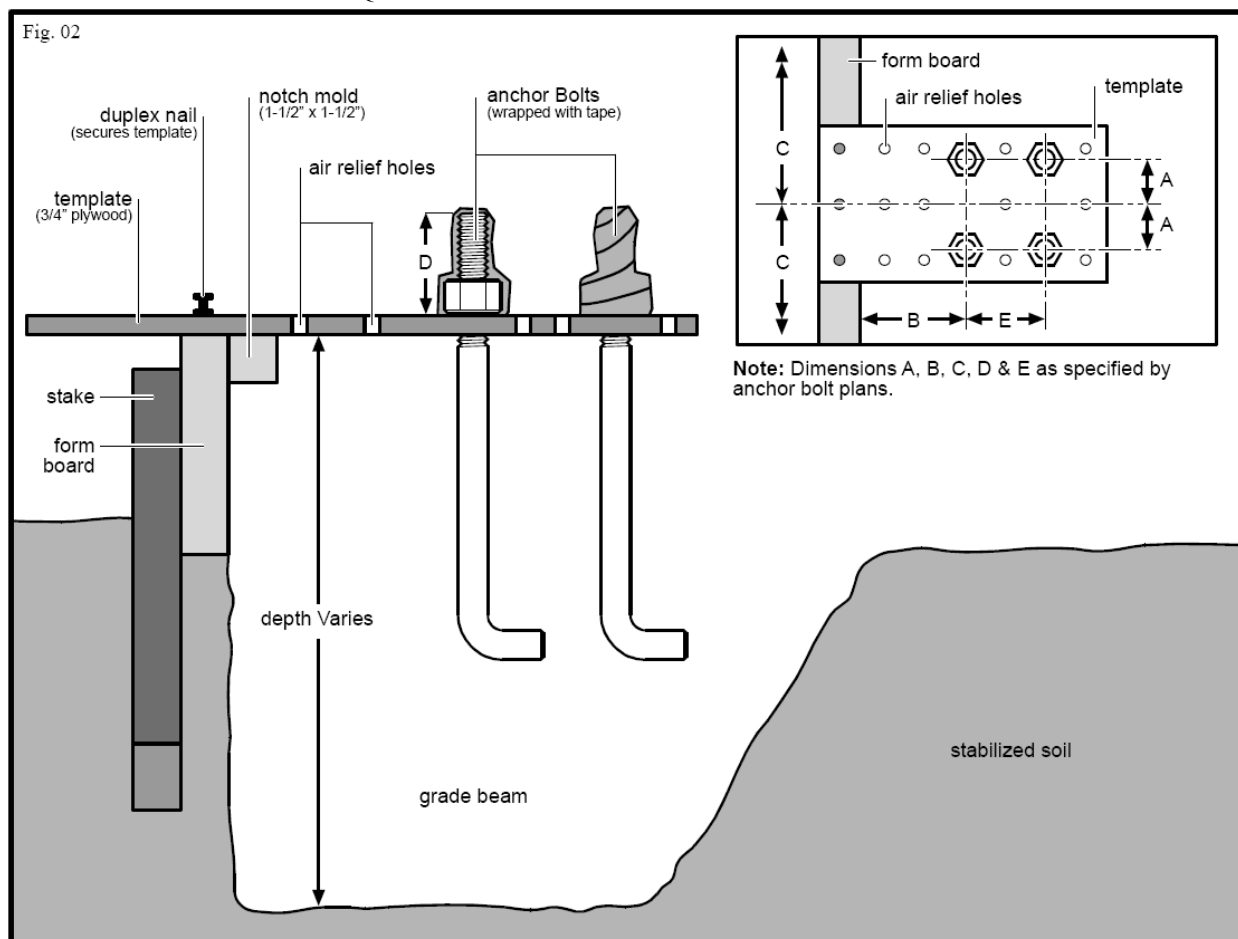

UNLOADING MATERIALS

Notice: The transport vehicle must gain access to the building site from the adjacent highway or road. Such access should be prepared in advance of arrival. All obstructions, overhead and otherwise, must be removed and the access route graveled or planked if the soils will not sustain the heavy wheel loads.

Notice: The availability of any required utilities should also be considered in advance. Take careful note of any overhead electric lines or other utilities to avoid hazards and damage (Notify your utility company(s) if necessary).

Tip: Protect the edges of the concrete from chipping or cracking due to truck traffic.

Safety Precaution: Materials stored on the slab proves efficient, but may subject workers to possible injury. Develop a comprehensive safety awareness program in advance to familiarize the work force with the unique conditions of the site, and the building materials, along with the appropriate "Safe Work" practices that will be employed.

SHIPMENT ARRIVAL TIME

Every effort will be made to see that the carrier arrives at the job site on the requested day and at the requested hour. Manufacturer makes no warranty and accepts no responsibility for costs associated with shipment not arriving at a requested time unless a separate agreement has been made in writing for the guaranteed arrival time.

SHIPMENT INSPECTION AND RECEIVING

3. Prior to unloading any material from the transport vehicle, perform the necessary inspections.

Notice: Upon shipment arrival, inspect for quantities and damages. Damaged or defective material, regardless of the degree of damage, must be noted on the shipping documents by the customer/builder and acknowledged in writing by the carrier's agent. The Manufacturer is not responsible for the material damaged in unloading, nor for packaged or nested materials, including but not limited to, fasteners, sheet metal, "C" and "Z" sections and covering panels that become wet and/ damaged by water, while in the possession of others. Packaged or nested material that becomes wet during transit must be unpacked, unstacked and dried by the customer/builder.

Notice: If the carrier is the manufacturer, the customer/builder, must make claim for damage directly to the manufacturer. The manufacturer is not liable for any claim whatsoever, including but not limited to, labor charges of consequential damages resulting from the Customer/Builder use of damaged or defective materials that can be detected by visual inspection. If any discrepancies are found, immediately file the necessary claims to the carrier then notify Lucas Metal Works® of the claim (918) 535-2726. Failure to perform the necessary inspections may result in settlement difficulties.

Excessive Material: The Manufacturer reserves the right to recover any materials delivered in excess of those required by the Order Documents.

Safety Precaution: To prevent injury from falling material, do not release the load tie-downs until confirmation has been made that the shipment is securely positioned and did not shift during transit.

4. PRE-PLAN THE STRATEGIC UNLOADING OF MATERIALS

Notice: Color coated, galvanized, and Galvalume materials provide excellent service under many weather conditions, but while stacked together these components are susceptible to damage from prolonged periods of contact with moisture. If there is evidence of moisture during unloading, the panels should be separated, dried, and stored out of the weather to prevent permanent discoloration. Discolored Galvanized steel is not a reason for reflection of material. Never install any material if its quality is in question. These panels are quality merchandise, which merits cautious handling. Prohibit people from walking on the components.

Do not handle panels roughly. Packages of panels must be lifted from the truck with extreme care to ensure that damage does not occur to the corners, sides or ribs.

Notice: While each job varies in size and condition, layouts will vary as well. Rigid frame columns and rafters are positions are rising while girts, purlins, endwalls columns and braces are positioned according to each bay.

4.1 As materials are unloaded, to minimize lifting and re handling during assembly, locate the parts near where they will be used. (Figure 03)

4.1.1. Unload and store all materials in a careful, safe and orderly manner. Job sites where storage space is restricted require detailed planning. By employing an efficient material layout plan, you can eliminate wasted time and costly double handling of materials. While set procedures are not possible in all cases, special consideration should be given.

Notice: Trucks are loaded to maximize efficiency, trailer weight and ensure safety. Unfortunately, the shipping department cannot load trucks per customer request. Exercise extreme caution when unloading materials. Beware of overhead obstruction and power lines.

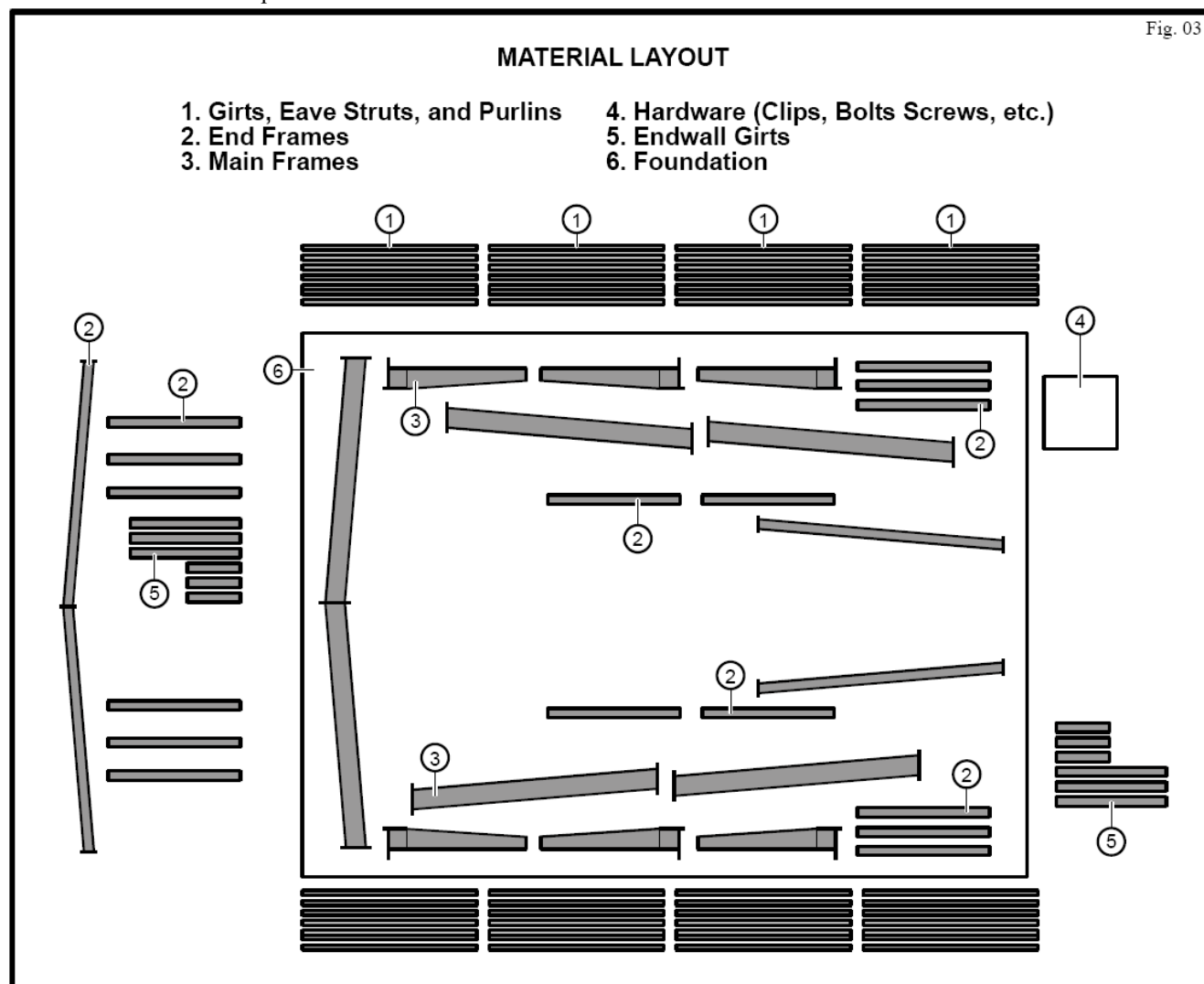

4.2 All parts are identifiable, but all secondary members are numbered for positive identification (purlins, girts, eave struts, door jambs, headers, etc.). To ensure the correct parts and quantities have been received, carefully compare part numbers to the shipping list(s). Note any discrepancies on the Bill of Lading, and the shipment is unloaded.

Notice: Panels, screws, clips, etc. are not numbered.

Tip: Keep in mind that once erection starts, crews and equipment must be able to maneuver accordingly.

Safety Precaution: To avoid damaging materials, exercise extreme care when unloading. A forklift or crane is necessary for unloading metal building components. A tractor with loading forks may be used as well. Unloading components should not be attempted with a small farm tractor. The weight of some bundled components may exceed 3,000 lbs.

-On a 30' x 40' building, bundled wall and roof panels may exceed 1,500 lbs.

-On a 30' x 40' building, bundled purlins and girts may exceed 1,000 lbs.

Notice: Bundled components are pre-arranged and coordinated for easy installation. For example: Endwell panels are stacked in a length-coordinated fashion, in groups of four, so that panel positioning is simplified. If bundles are broken out and separated. It may prove difficult for matching components to the proper locations (s).

4.3 To prevent long panels from bending, spread the forks as wide as possible. At times, it may be necessary to lift loads with a crane and spreader bar. (Figure 4)

Fig. 04

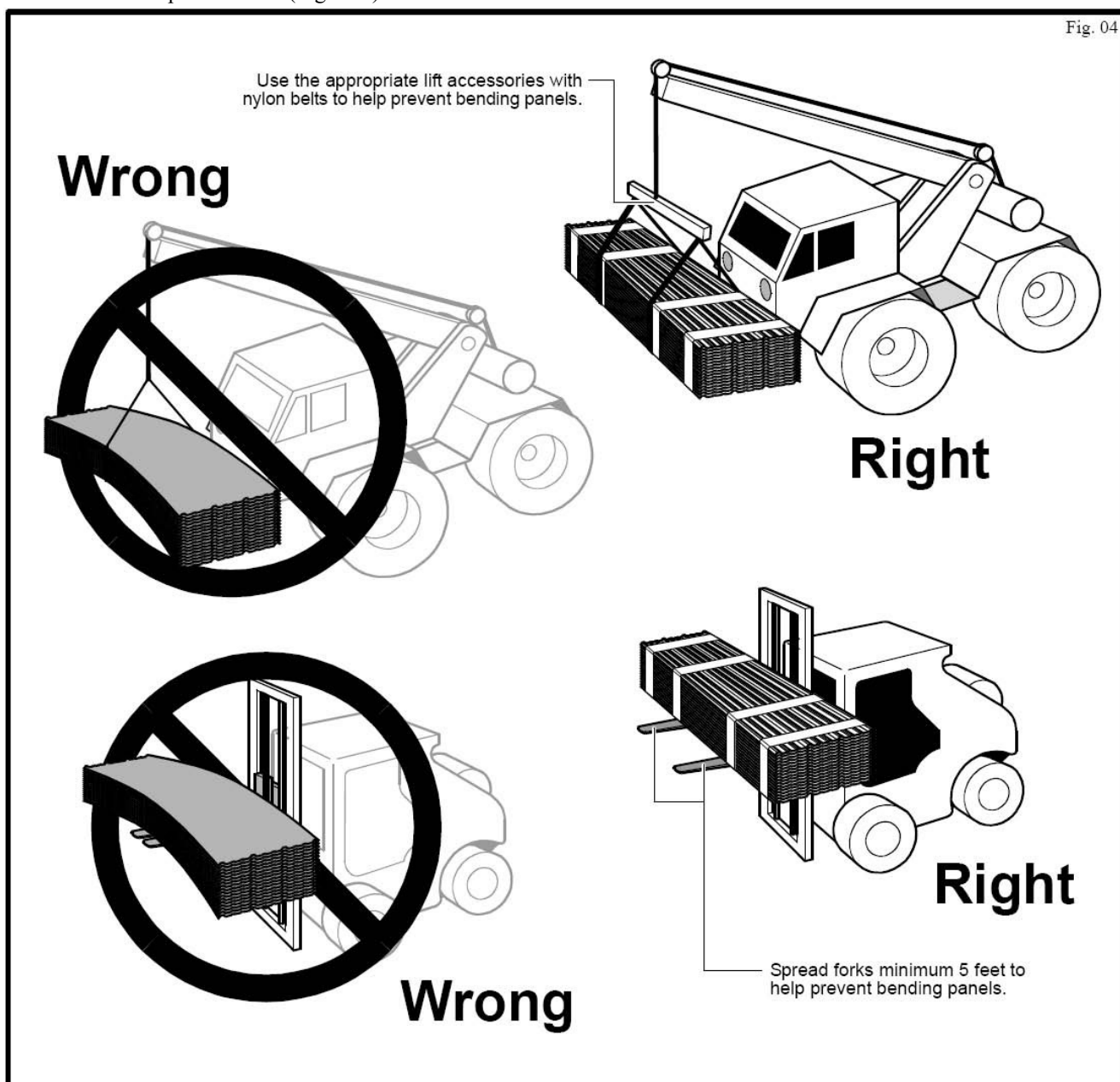

4.4 To encourage water drainage and allow air circulation, use wood blocking (i.e. 2 x 4s, 2 x 6s, 4 x 4s, etc.) to elevate building components. To prevent panel bending and warping, do not space wood blocking more than 7 feet apart. (Figure 05)

4.4.1. All material such as panels, purlins, girts, etc. must be stored on a slight angle.

4.4.2. Rigid frame columns/rafters must be stored vertically on a slight angle.

Tip: Blocking under the columns and rafters helps to protect the base plates, splice plates, and foundation from drainage during unloading and handling. It also aids in placing slings or cables around the members for later lifting.

4.5 To help keep components dry, cover and secure all material with plastic tarp(s).

Notice: Use a tarp to keep material dry while in storage. If water remains on painted or coated surfaces for an extended period of time, corrosion will occur, therefore shortening material life.

Tip: All primered surfaces should be touched up before and after erection.

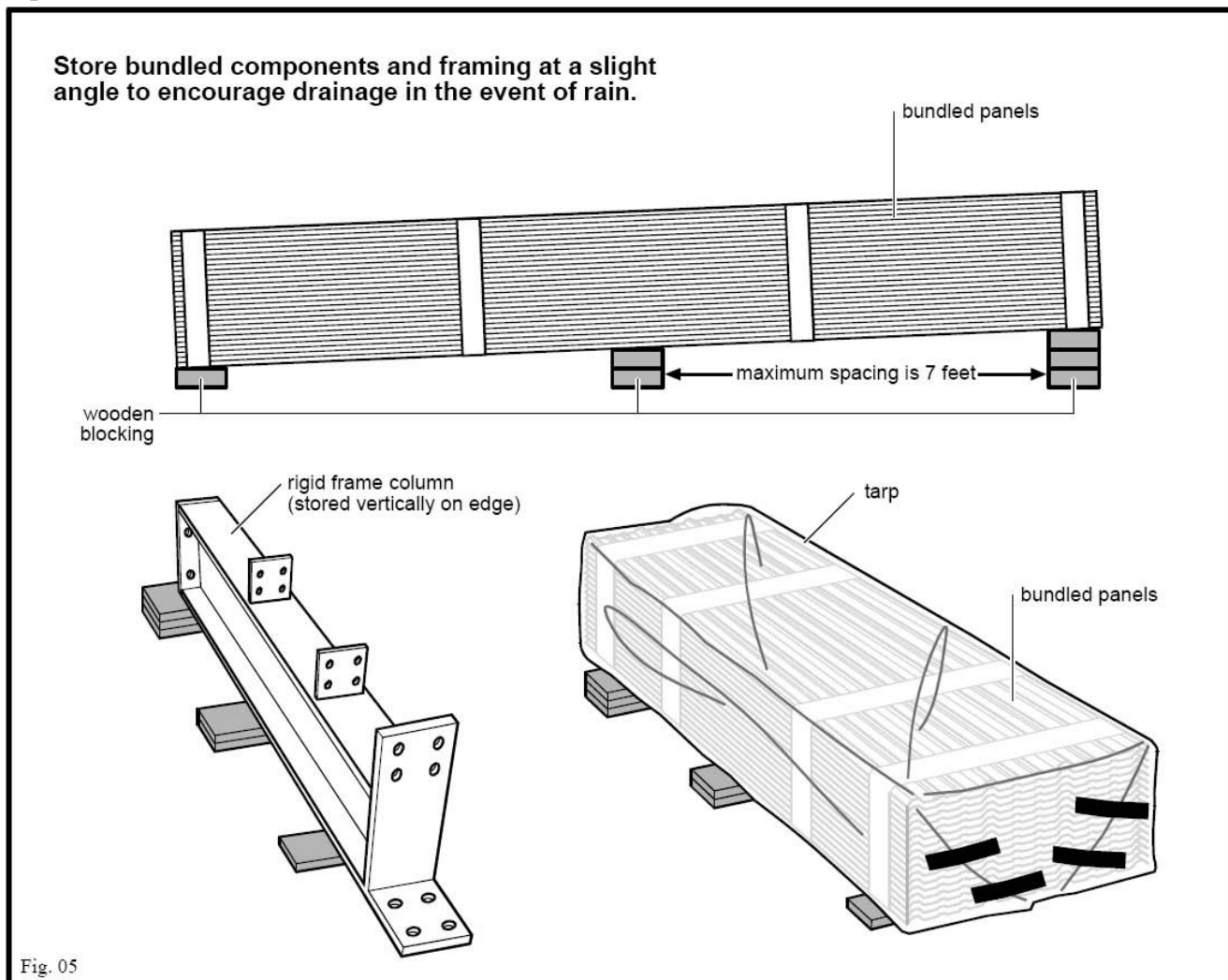

GENERAL HOISTING INFORMATION

Safety Precaution: To help prevent injury, material damage, project delay, or additional costs, only experienced personnel in light steel member rigging, and lifting should any necessary hoisting, assembly, and steel erection procedures.

Safety Precaution: Inspect ropes/cables for integrity and load range(s). If any defects or load range discrepancies are identified, do not use for lifting. Replace defective lifting equipment immediately.

TENSION AND HOOK HEIGHT DIAGRAM FOR LIFTING WEIGHTS AT VARIOUS ANGLES.

(Figure 06) Notice: As lift angles decrease, cable tension increases, therefore increasing compression on the load. To help protect the cable and load from damage, avoid low sling lift angles.

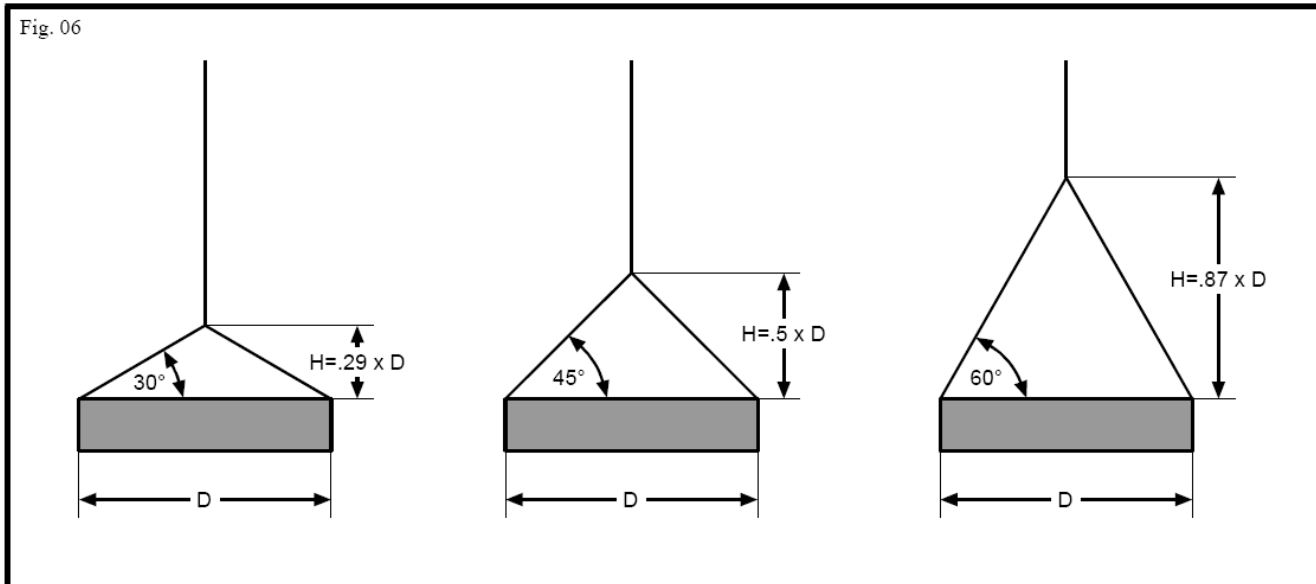

STRUCTURAL FRAMING PRIMER

The primer supplied by Lucas Metal Works® is not intended to provide the uniformed finish coat nor will it provide extended protection if subjected to prolonged outdoor exposure. If immediate erection of the building cannot be performed, all components must be protected from exposure to environmental conditions that may promote degradation to primer performance. These conditions would include, but not be limited to, prolonged exposure to ultra-violet light due to possible fading and or standing water resulting in spotting, peeling or localized surface oxidation.

THE MBMA COMMENTARY STATES THAT:

“...the manufacturer is not responsible for the deterioration of the shop coat of primer or corrosion that may result from exposure to atmospheric and environmental conditions, nor the compatibility of the primer to any field applied coating...”

THE AISC, CODE OF STANDARD PRACTICE FURTHER STATES THAT:

“...the shop coat of paint is the prime coat of the protective system. It protects the steel for only a short period of exposure...”

Due to transit abrasions and/or scratching during loading, unloading, and handling, primer touch-up will be necessary. Primer touch-up is the responsibility of Customer/Builder. Additional guidelines for the handling and storage of steel components can be found in both the MBMA Commentary and AISC Code of Standard Practice.

The factory primer is only intended to protect the steel framing for short time exposure to ordinary outdoor conditions. The coat of shop primer does not provide the uniformity of appearance, or the durability and corrosion resistance of a field applied finish coat of paint over a shop primer. The Manufacturer is not responsible for deterioration of the factory primer or corrosion that may result from neither exposure to outdoor conditions or the compatibility of the primer coat applied in the field.

WALL AND ROOF PANELS

Safety Precaution: When handling metal panels, wear gloves to help prevent hand injuries. Exercise extreme caution when handling panels on windy days. Panel can catch wind and knock a worker down, even at ground level.

Safety Precaution: Panels are slippery. Oil or wax may have been applied to the roof and wall panels. Exercise extreme caution when walking on panels. Always walk in the flat parts of the panel. Wipe the panels free of any oil or residue, condensation, dew, frost, or other forms of moisture greatly increase the slickness of the panels. Always assume panel surfaces are slippery and take the appropriate safety precautions. Never walk or step on light transmitting panels or translucent panels!

Important: Rough edges may damage finishes when sheets are slide across and another. Never allow panels to be walked on while on the ground.

ASSEMBLE STRUCTURAL STEEL

GENERAL INFORMATION

Many methods and procedures are utilized for erecting metal buildings. The installation procedures employed depend on the crew experience level, type of building, available equipment, and working conditions.

Important: Do not install any building components if quality or integrity is in question. The manufacturer will not be responsible for incurred costs associated with the installation and/or removal of the questionable material.

Unique conditions and factors override all set installation rules and procedures. The builder must tailor installation procedures to fit individual conditions and requirements. However, certain installation practices pertaining to structural members have proven sound and should be employed.

Installers must not alter any primary or secondary framing members (rigid frame columns, rafters, end bearing frame rafters, interior columns, or otherwise). These are the primary support members for the frame and are designed as such. Any alteration to the primary support members will affect the structural stability and void any and all warranties. A representative of Lucas Metal Works® must be consulted prior to attempting alterations of these members.

Notice: This manual is only a general guide and does not address other acceptable installation procedures. Installation and safety practices are the Builder's responsibility. In all cases, the Builder must comply with applicable safety precautions whether statutory, regulatory, or customary. This manual explains procedures generated from general practice and may not apply in every case. Even the most common practices may result in injury or improper installation if not conducted properly and under the supervision of an appropriate professional. The manufacturer will not be held liable or responsible for problems stemming from improper installation.

RECOMMENDED TOOLS

Safety Precaution: Purchase only industrial rated, top quality tools for building installation. High-speed drill bits are recommended. Maintaining equipment and tools in safe, clean condition reduces injuries, lowers replacement expense, and encourages workers to take pride in their work.

Safety Precaution: Make certain that the correct tool is utilized for each phase of assembly. Improper tool usage may result in injury. All tools used should be OSHA approved for commercial construction use.

ERECT SIDEWALL COMPONENTS

5. Prepare to erect all sidewall rigid frames, girts, and eave struts.

Important: Before beginning any installation procedures, check anchor bolt dimensions against the Anchor Bolt Plan.

Important: All rigid frame sidewalls must be erected first (see step 8). Rafters and purlins will be installed second (see step 9). The endwalls will be installed last (See step 14).

Safety Precaution: Position temporary bracing material for easy access. Sidewall columns may require supplemental bracing prior to securing with hardware.

Safety Precaution: Bolt in place as many clips and flange braces as possible before raising frame to reduce in-the-air installation time.

5.1 Lay out rigid frame sidewall columns, girts, and eave struts. (Figure 07)

5.2 Erect all rigid frame sidewall columns then snugly attach the base plate mounting hardware.

Tip: Do not tighten mounting hardware at this time. Column adjustments may be required.

6.2.1. If necessary, attach supplemental bracing to the rigid frame sidewall columns.

5.3 Install all sidewall girts then hand-tighten the mounting hardware.

5.4 Install all eave struts then hand-tighten the mounting hardware.

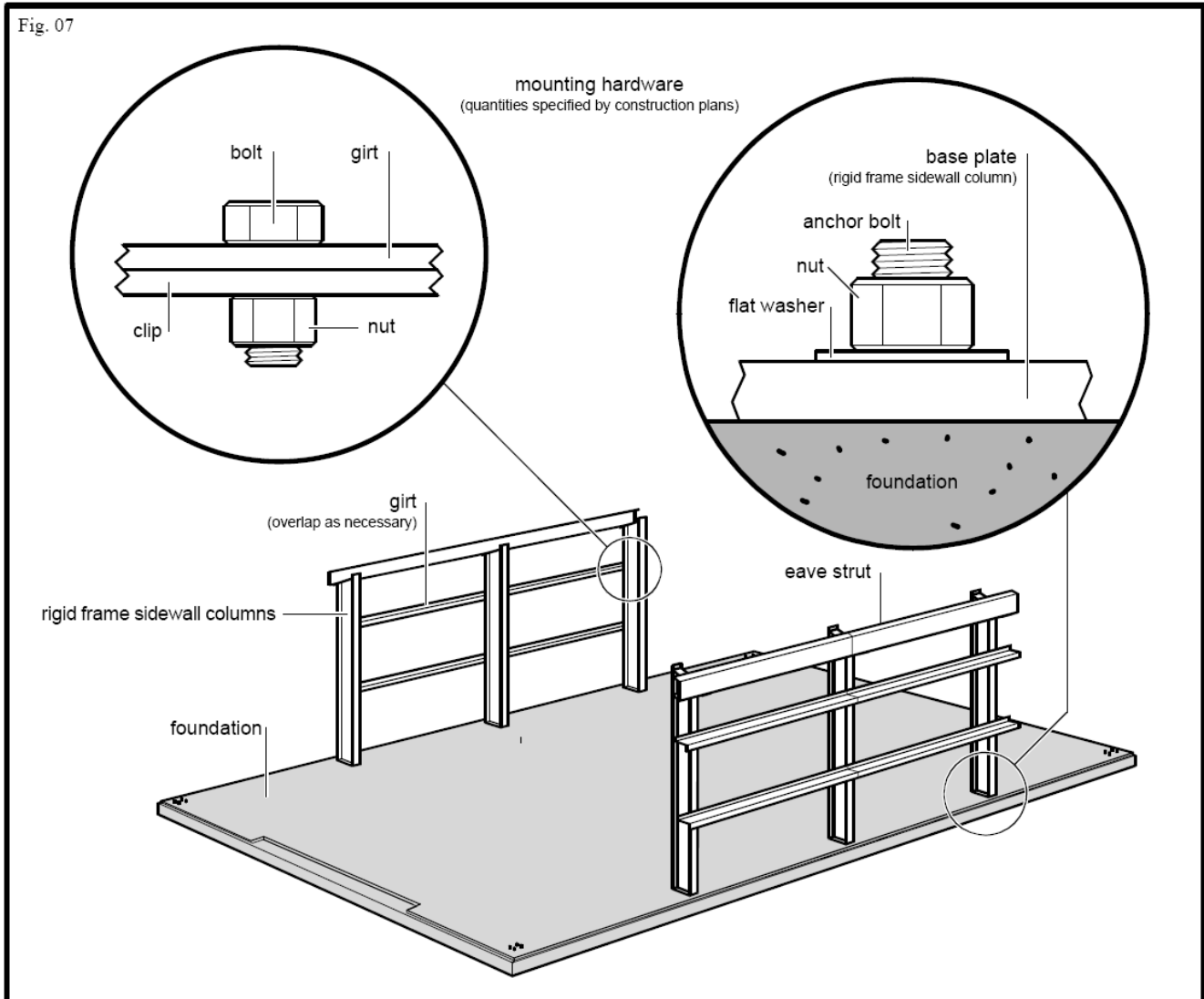

INSTALL ROOF COMPONENTS AND CABLE BRACING

6. Prepare to install the rafter assemblies, purlins, and cable bracing (if applicable). (Figure 08)

6.1 Lay out all rigid frame rafters, and purlins.

6.2 Assemble all rigid frame rafters, while laying on the foundation, then securely tighten all peak splice plate hardware.

6.3 Using the proper lift equipment, install one of the rafter assemblies nearest to the center then snug the haunch splice plate mounting hardware.

6.4 As neighboring rafters are installed, complete the bay by installing purlins and cable bracing with all mounting hardware hand-tight.

Safety Precaution: Stabilize each bay as it is completed by insuring that all girts, eave struts, purlins, and cable braces are in place.

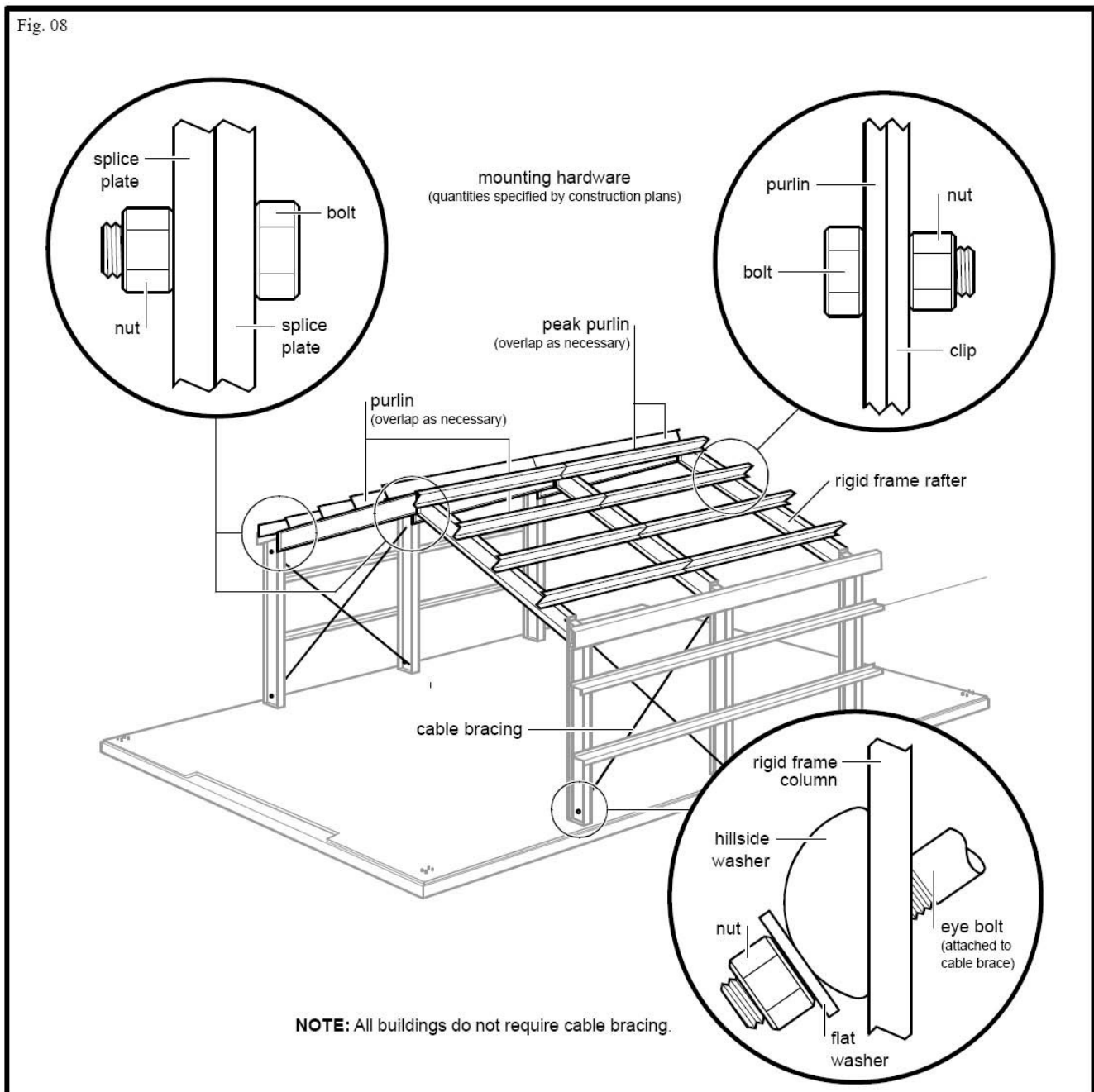

PLUMB, SQUARE, AND SECURE THE RIGID FRAMES AND BAYS

Important: All structural bolts shall be tightened by the “turn-of-the-nut” method In accordance with the 9th Edition AISC “Specification for Structural Joints”.

Tip: While making any needed adjustments, use shims if necessary.

7. Prepare to plumb and secure the rigid frame nearest to the building’s center. This frame is referred to as the primary frame”. (Figure 09)

7.1 Plumb the sidewall column nearest to the building’s center then tighten the base plate mounting hardware as necessary in a “turn-of-the-nut” method.

7.2 While maintaining proper height, plumb the rafter then tighten the haunch splice plate mounting hardware as necessary in a “turn-of-the-nut” method.

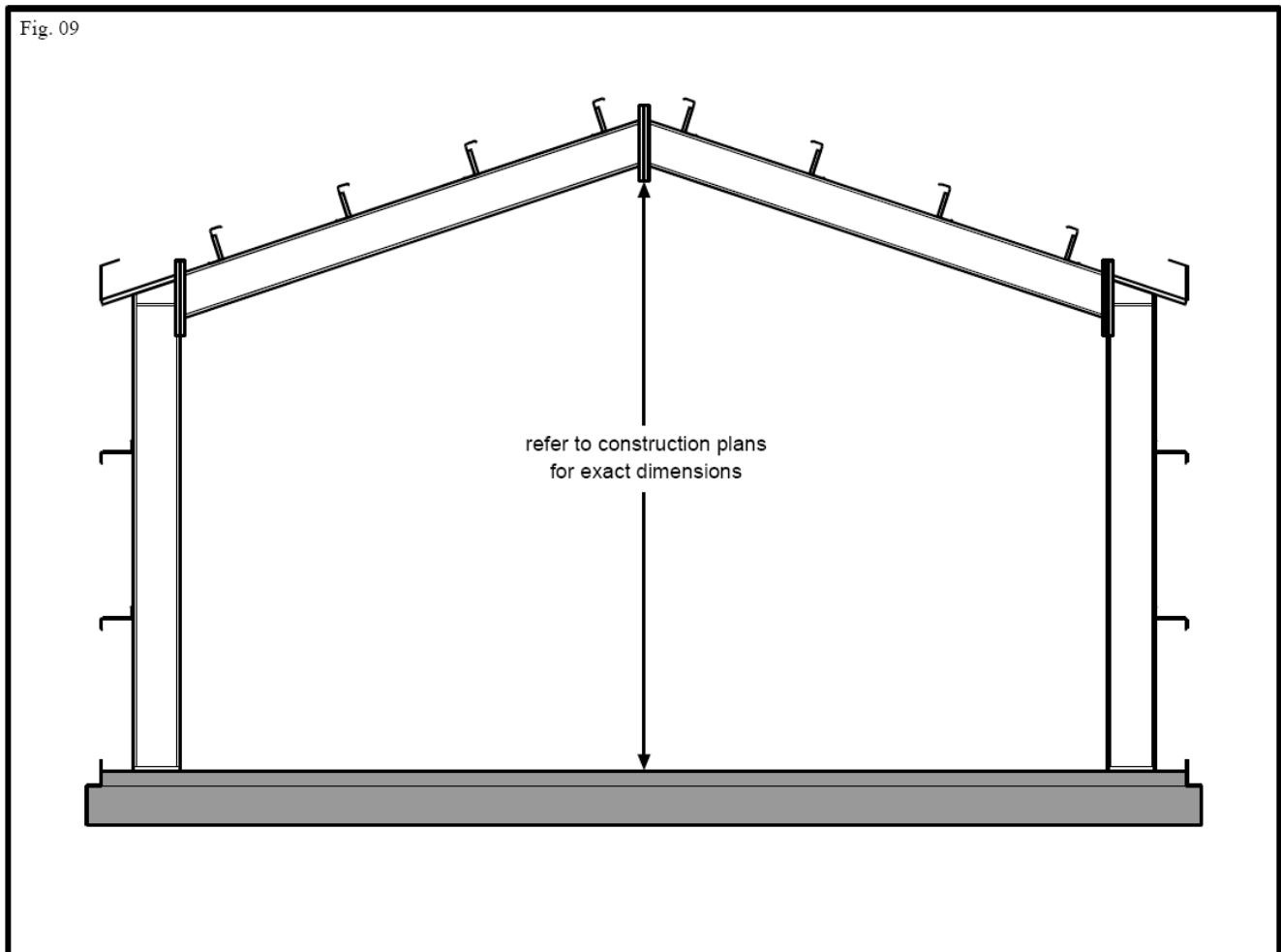

8. Prepare to plumb, square, and secure the neighboring bay. (Figure 10)

- 8.1 Plumb the neighboring sidewall column nearest to the building's center then tighten the base plate mounting hardware as necessary in a "turn-of-the-nut" method.
- 8.2 Square the rigid frame assembly to the primary frame.
- 8.3 While maintaining proper height, plumb the rafter then tighten the haunch splice plate mounting hardware as necessary in a "turn-of-the-nut" method.
- 8.4 Repeat this step until all rigid frames are plumb and secure.

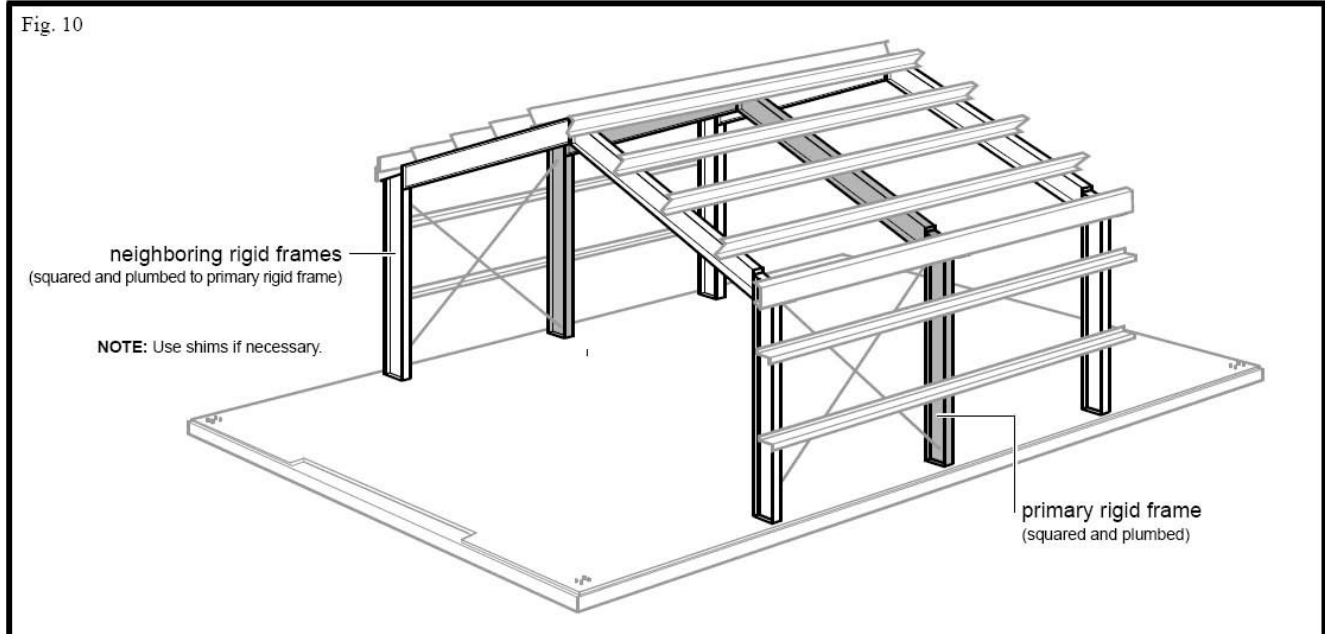

9. Prepare to check all rigid frames for plumb and square. (Figure 11)

- 9.1 Using a measuring tape, measure the "A to C" dimensions. It should be the same as the "B to D" dimension.
- 9.2 Using a measuring tape, measure the "A to E" dimensions. It should be the same as the "B to F" dimension.

Notice: If dimensions are not equal, make the necessary adjustments before securing the cable bracing.

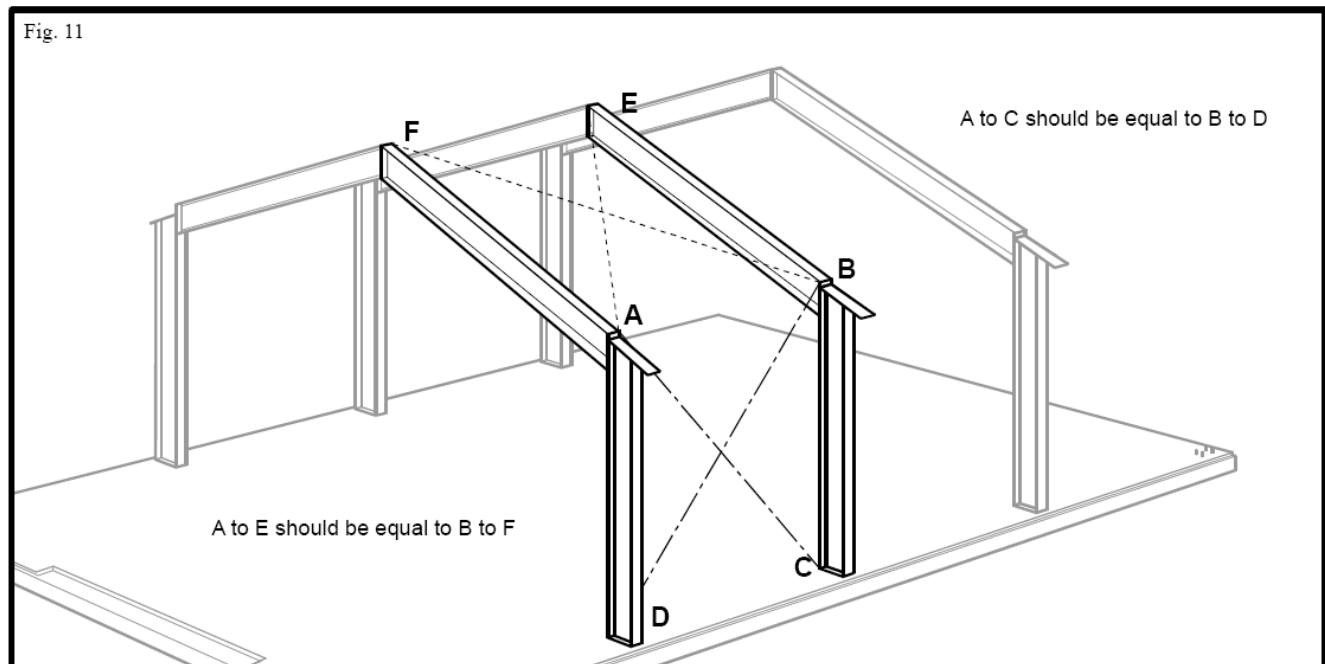

10. Prepare to tighten the bay's cable bracing.

Notice: the primary function of cable bracing is to serve as a backup support system in the unlikely event of diaphragm failure.

10.1 All cable bracing should be tightened evenly, as necessary. Do not over tighten.

Erect Endwall Component

Notice: Some buildings utilize rigid frames for the endwall; therefore endwall frames will not be erected. This is usually the case if the owner plans to extend the building at a future time.

11. Prepare to add the endwalls, girts and rafters. (Figure 12)

11.1. Lay out all endwall columns, girts and rafters.

11.2. Erect all endwall columns then snugly attach the base plate mounting hardware.

Tip: Do not tighten mounting hardware at this time. Column adjustments may be required.

11.2.1 If necessary, attach supplemental bracing to the endwall columns.

11.3 Install all endwall girts and remaining sidewall girts then hand-tighten the mounting hardware.

11.4 Install all endwall rafters then hand-tighten the mounting hardware.

11.5 Repeat this step for the remaining endwall.

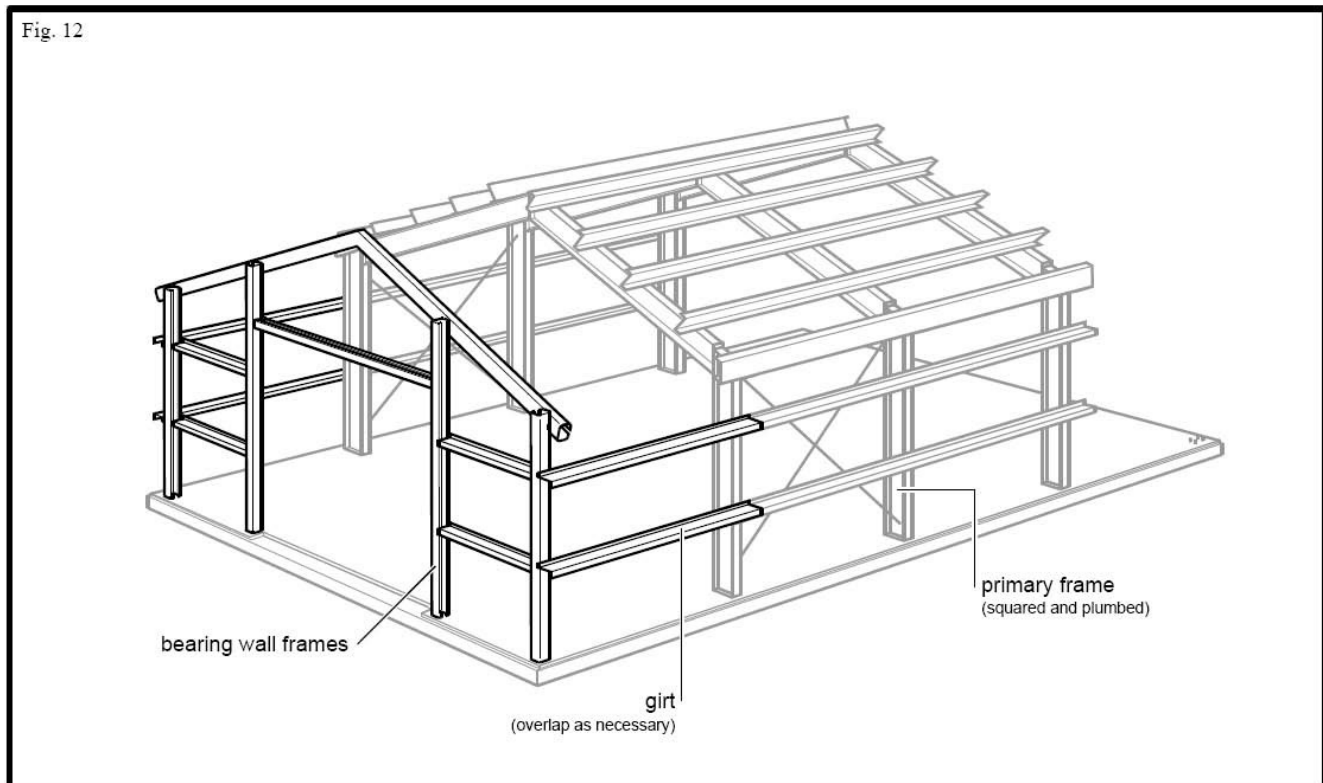

PLUMB, SQUARE, AND SECURE THE ENDWALL FRAMES

12. Prepare to plumb and secure the endwalls. (Figure 13)

12.1 Plumb the endwall columns then tighten the base plate hardware as necessary in a “turn-of-the-nut” method.

12.2 Install the endwall rafters then hand-tighten the mounting hardware.

12.3 Install the remaining purlins and eave struts.

12.4 Tighten all hardware as necessary. Use the “turn-of-the-nut” method where applicable.

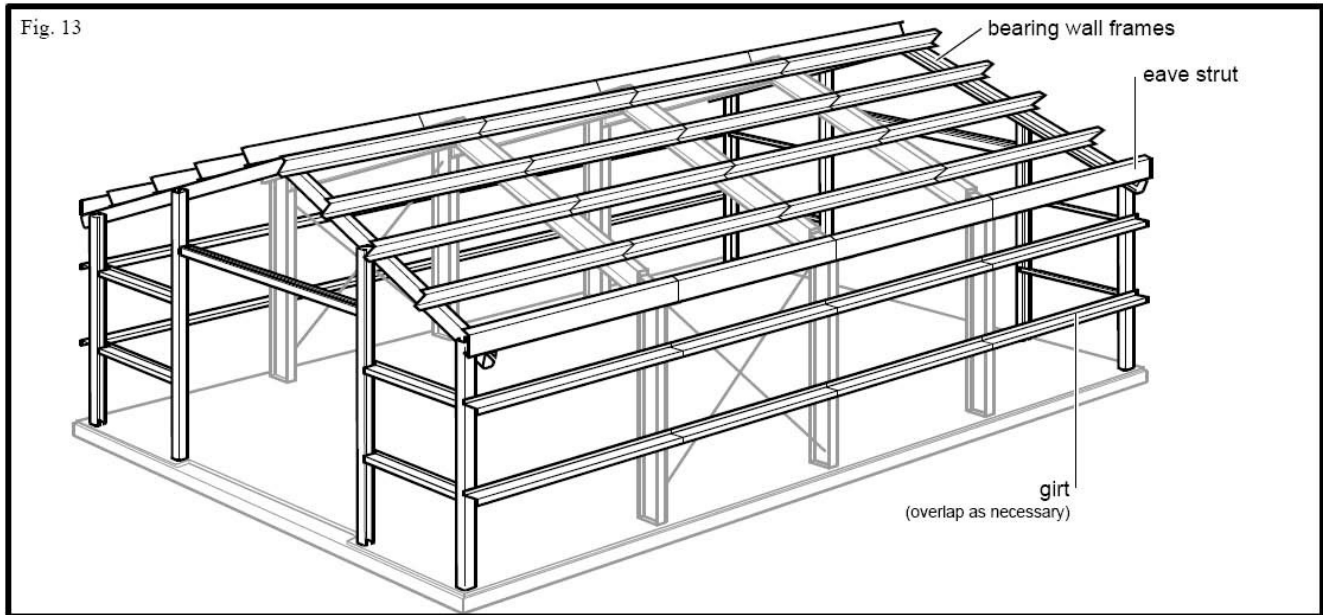

INSTALL FRAMED OPENINGS

Important: All Structural bolts shall be tightened by the “turn-of-the-nut” method in accordance with the 9th Edition AISC “Specification for Structural Joints”.

After the frame is complete, install all framed openings for doors, windows, etc. (Figure 14)

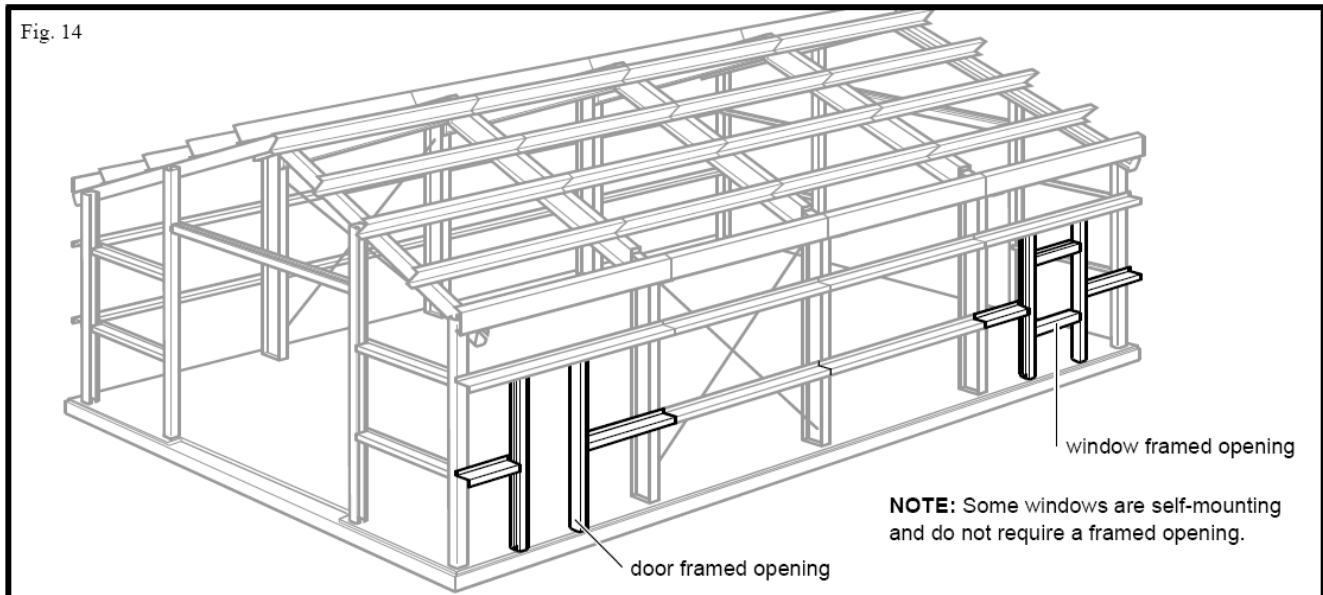

INSTALL BASE-ANGLE AND RAKE ANGLE

13. Install the base-angle around the concrete slab, except for in designated openings, (Figure 15)

Notice: The base-angle provides a solid mounting surface for the bottom of the wall panel.

13.1. Use concrete anchors to secure the base angle to the slab. (See Construction Drawings for the relative specifications.)

13.1.1. Install the concrete anchors every 2 feet and no closer than 2" from the end of the base angle.

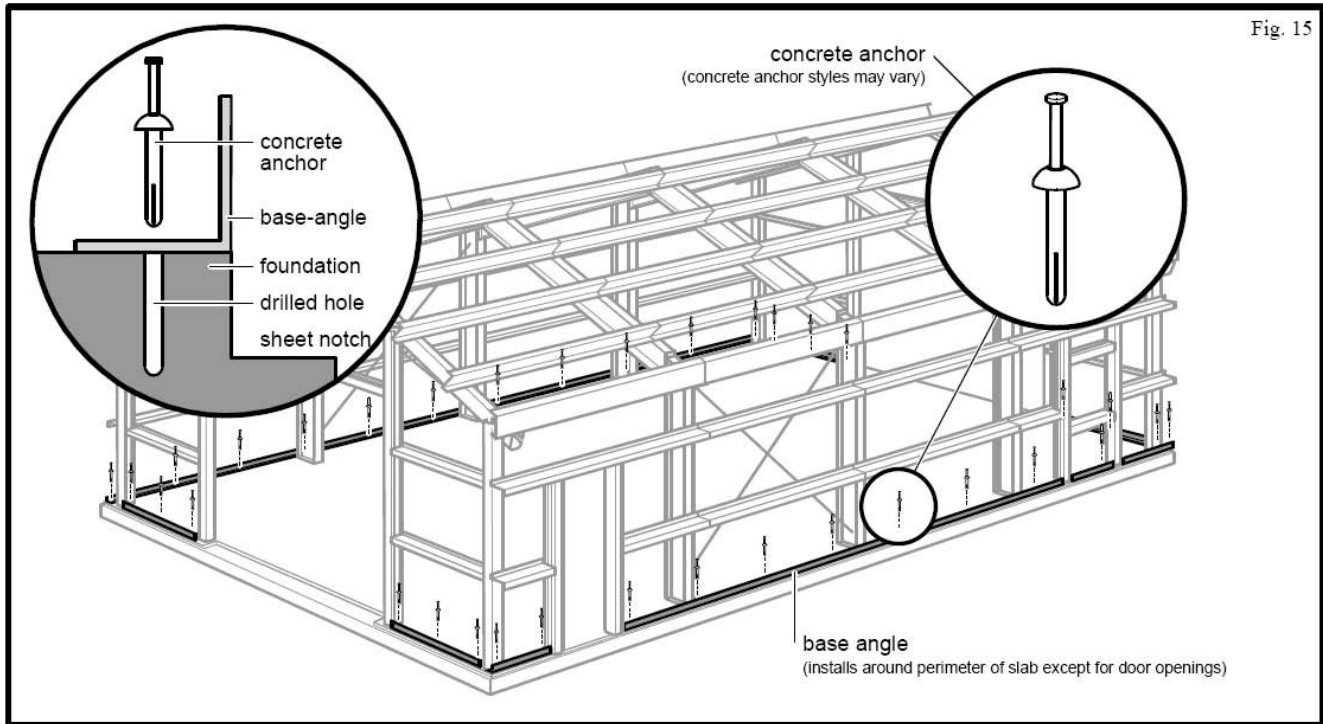

FINAL FRAME BOLT INSPECTION

14. Prepare to conduct the final bolt inspection.

Important: Confirm all structural connections have the required quantity, size and type (s) of bolts and they are all properly tightened.

Important: Structural bolts shall be tightened by the “turn- of- the- nut” method in accordance with the 9th Edition AISC “Specification for the Structural Joints”.

14.1. Using a “turn-of-the-nut method”, start at the base plates then working up through the splice plates and tighten all mounting hardware as necessary.

14.2. Using a “turn-of-the-nut method” where applicable, tighten all other mounting hardware as necessary.

14.3. To prevent rusting, apply touch-up primer to any scratched or field modified areas.

SUPPORT GIRTS FOR PANEL INSTALLATION (figure 17)

Fig. 17

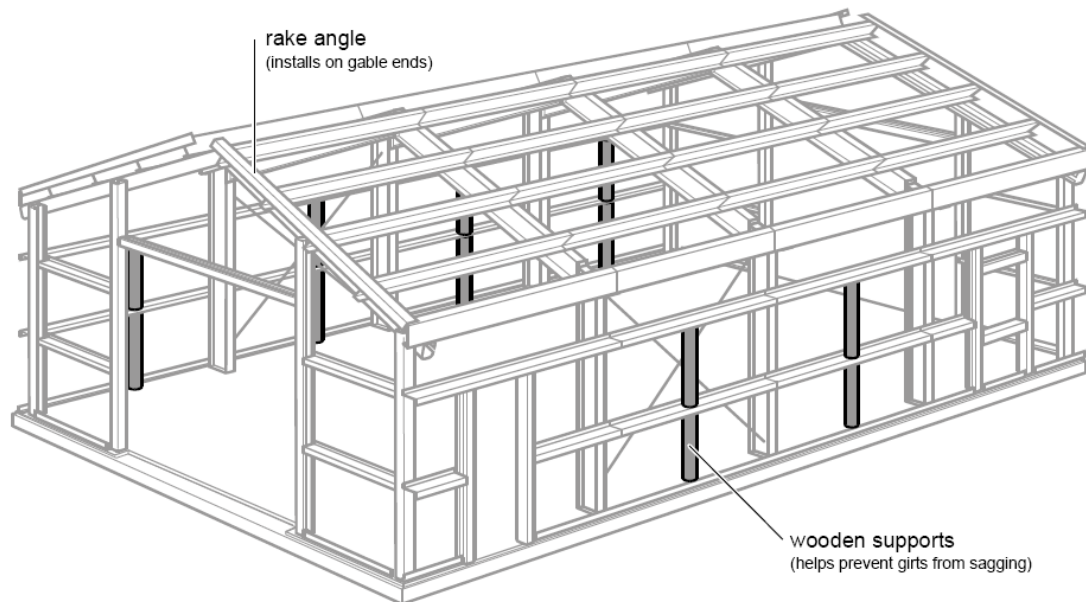

INSTALL WALL INSULATION, PANELS, CORNER TRIM, AND EAVE TRIM/GUTTER COUNTER FLASHING

PANEL DESCRIPTIONS (FIGURE 18)

“R” Panel -Designed for both roof and wall applications. Its symmetric profile allows for panel installation without regard to sheathing direction. Sheeting can be started from either end of the building, in areas where there is a high prevailing wind, run the laps with the wind.

“PBR” Panel-Designed for roof applications but can be used as a wall panel. It’s profile is identical to the “R” panel except for the extended support leg on the leading edge of the panel: which provides better nesting with the overlapping rib of the next panel.

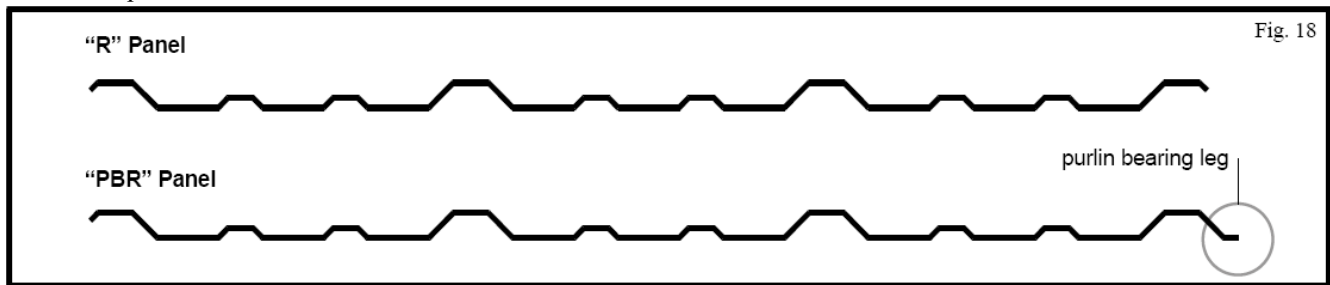

WORKSITE PREPARATION

15. Prepare the work site for insulation and wall panel installation.

Safety Precaution: As panels are distributed around the building, prevent wind from blowing them around by securing them as necessary.

15.1. Layout all sidewall and endwall panels (in stacks of 10 minimum; for pre-drilling) nearest where they will be installed. (Figure 19)

15.2. To prevent being blown by wind, secure the panel stacks as necessary.

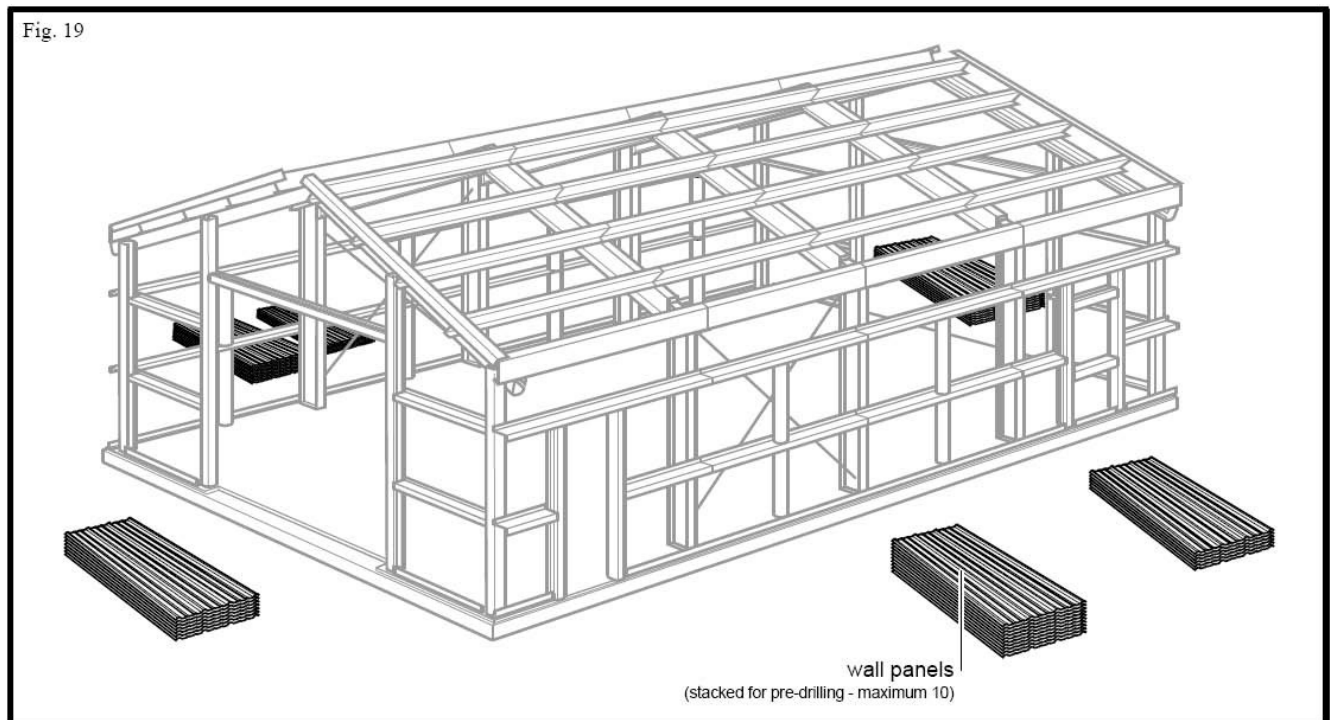

PRE-DRILL SIDEWALL PANELS

16. Prepare to predrill “sidewall” panels for easy installation.

Due to the manufacturing process, oil may have been applied to protect panels. Prior to installation, use an approved cleaner to wipe panels free of foreign debris and residue.

Safety Precaution: Wear OSHA approved eye protection when operating drill. Electric tools must be properly grounded. Do not use electrical equipment while standing on wet surfaces.

Warning: Reverse rolled panels require different screw patterns. Refer to the construction drawings for proper screw placement.

Lap Screw Detail Tip: Evenly aligned and distributed wall panel screws will yield a professional appearance. Drill the 1/8” lap screw clearance holes down the center of the high lap rib on 30” centers or as specified by the erection drawings (drill the first hole 2 1/2 “ from the bottom edge then distribute as necessary). For cosmetic reasons, place the lap screw clearance holes in the center of the panel’s high lap rib.

16.2 To confirm the proper panels are being pre-drilled, measure the panels then compare them to the area(s) to be covered. (Figure 20)

16.2.1. Using a measuring tape, measure the panel length, which is the “A” to “B” dimension.

16.2.2. Using a measuring tape, measure from the bottom of the foundation notch to the notch of the eave strut, which is the “C” to “D” dimension.

Notice: The “A” to “B” measurement should be approximately 1” shorter than the “C” to “D” measurement

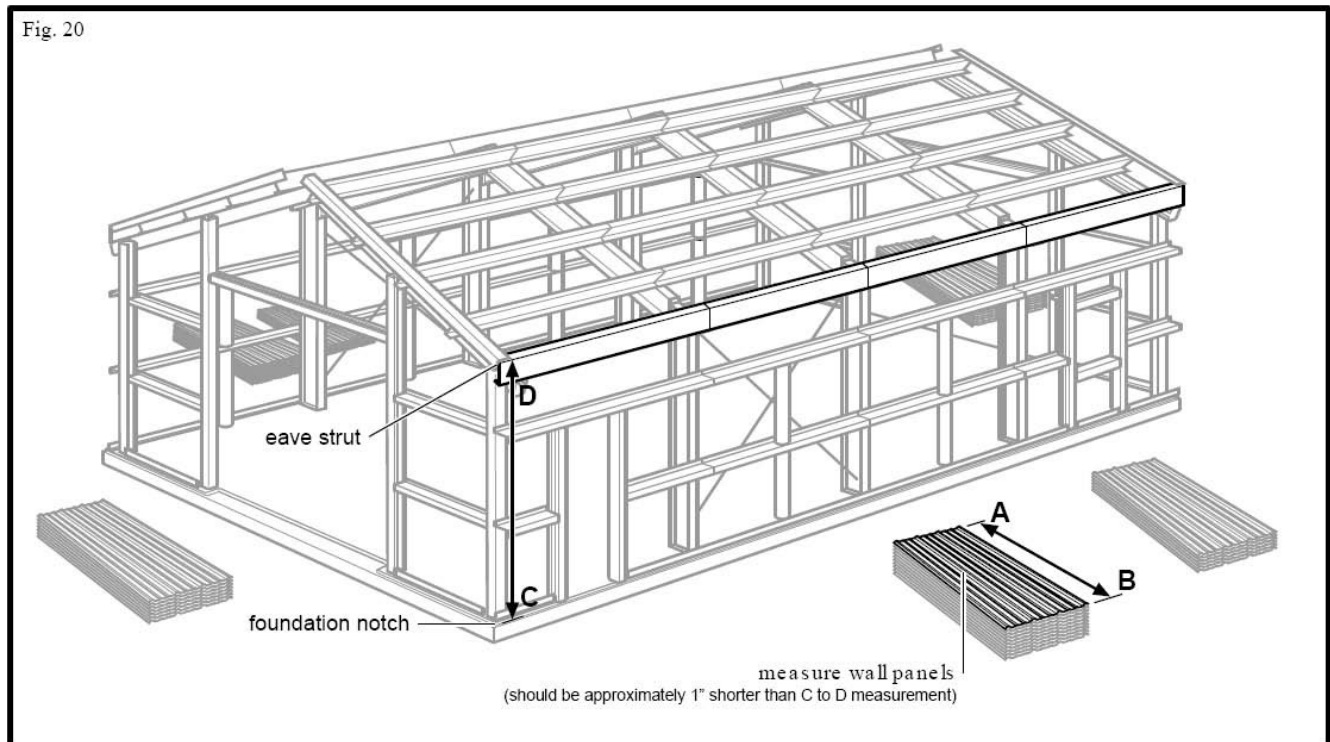

16.3. Prepare to pre-drill the “sidewall” lap screw clearance holes. (Figure 21)

Important: Lap screw centers are different between sidewall panels and roof panels. Pay attention to the details.

Important: To help protect the panels’ finished surfaces, place protective material between the jaws of the vice grip clamps.

- 16.3.1.** With the panels pre-arranged in stacks of ten and perfectly aligned, use vice grip clamps to secure the stack in preparation for drilling. This will help prevent misalignment.
- 16.3.2. (Refer to the illustration for sidewall lap screw clearance hole placement)** Using a writing utensil and measuring tape, mark the first hole location 2 1/12” to the bottom of the panel lap rib then distribute the remaining clearance holes on 20” centers, or as specified by the erection drawings, with the last hole 1” from the top of the panel.
- 16.3.3.** Using a 1/8” drill bit, carefully drill holes through the panel stacks at the marked locations.

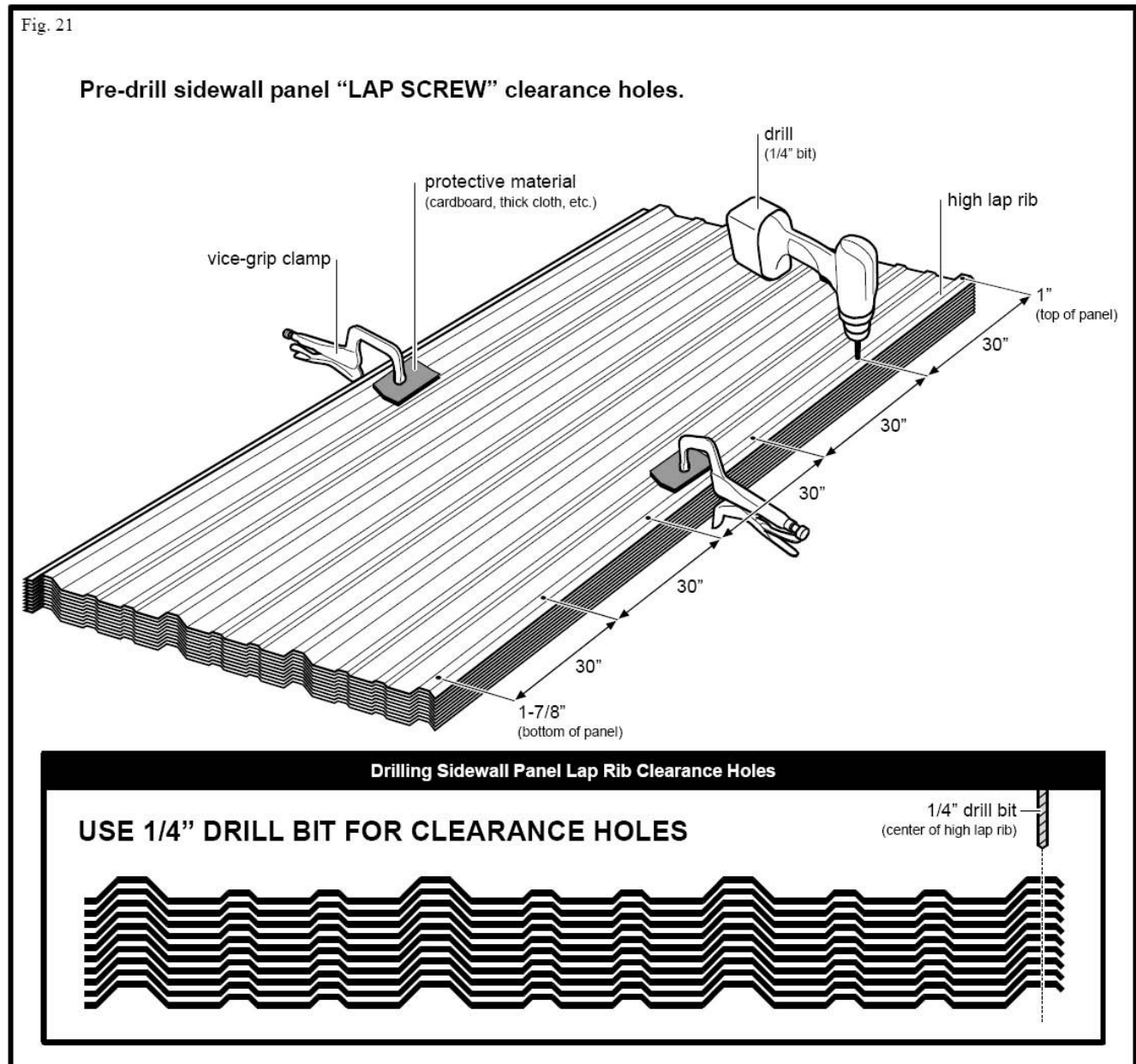

16.4. Prepare to pre-drill the “sidewall” base-angle pilot holes. (Figure 22)

Base-Angle Detail Tip: Evenly aligned and distributed panel screws will yield a professional appearance. Drill the 1/8” base-angle screw pilot holes, according to diagram below, or as specified by the erection drawings. For cosmetic reasons, place the pilot holes in the center of the panel “flats”.

- 16.4.1.** (Refer to the illustration for “sidewall” base-angle screw pilot hole placement.) Using a writing utensil and measuring tape, mark the first hole 2 1/2 “ from the bottom edge of the panel, in the center of the “flat” next to the high ribs.
- 16.4.2.** Distribute the remaining pilot holes, according to the diagram below, or as specified by the erection drawings.
- 16.4.3.** Using a 1/8” drill bit, carefully drill holes through the panel stacks at the marked locations.

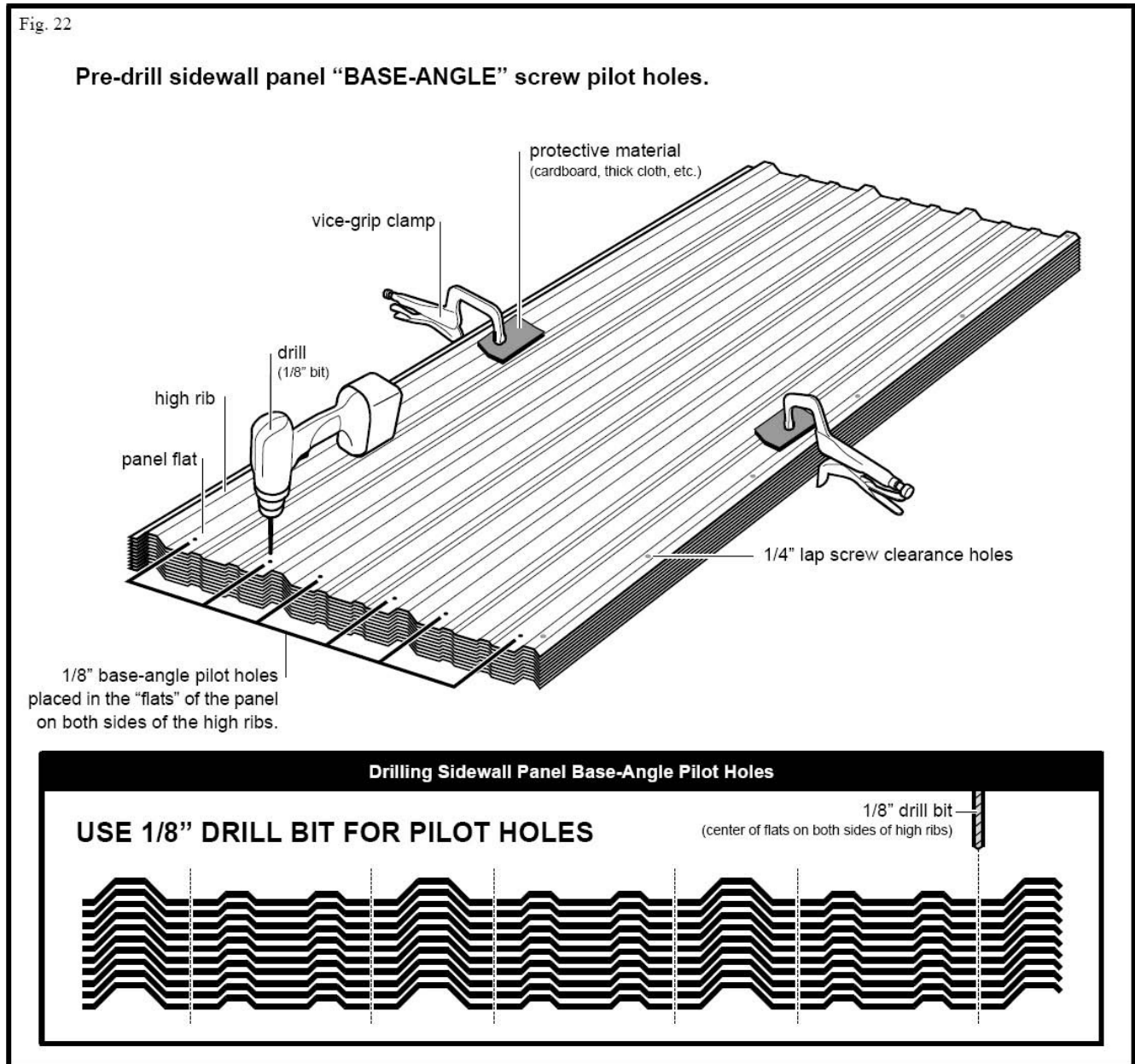

16.5. Prepare to pre-drill the “sidewall” girt screw pilot holes. (Figure 23)

Girt Screw Detail Tip: Evenly aligned and distributed panel screws will yield a professional appearance. Drill the 1/8” girt screw pilot holes on approximately 12” centers or as specified by the erection drawings. For cosmetic reasons, place the girt screw pilot holes in the center of the panel “flats”.

16.5.1. Using a measuring tape, measure from the bottom of the foundation notch to the center of the girt line (s).

16.5.2. (Refer to the illustration for “sidewall” girt screw pilot hole placement.) Using a writing utensil and measuring tape, mark the first hole (s) next to the lap rib in the center of the “flat” as shown then distribute the remaining pilot holes on 12” centers or as specified by the erection drawings .

16.5.3. Using a 1/8” drill bit, carefully drill holes through the panel stacks at the marked locations.

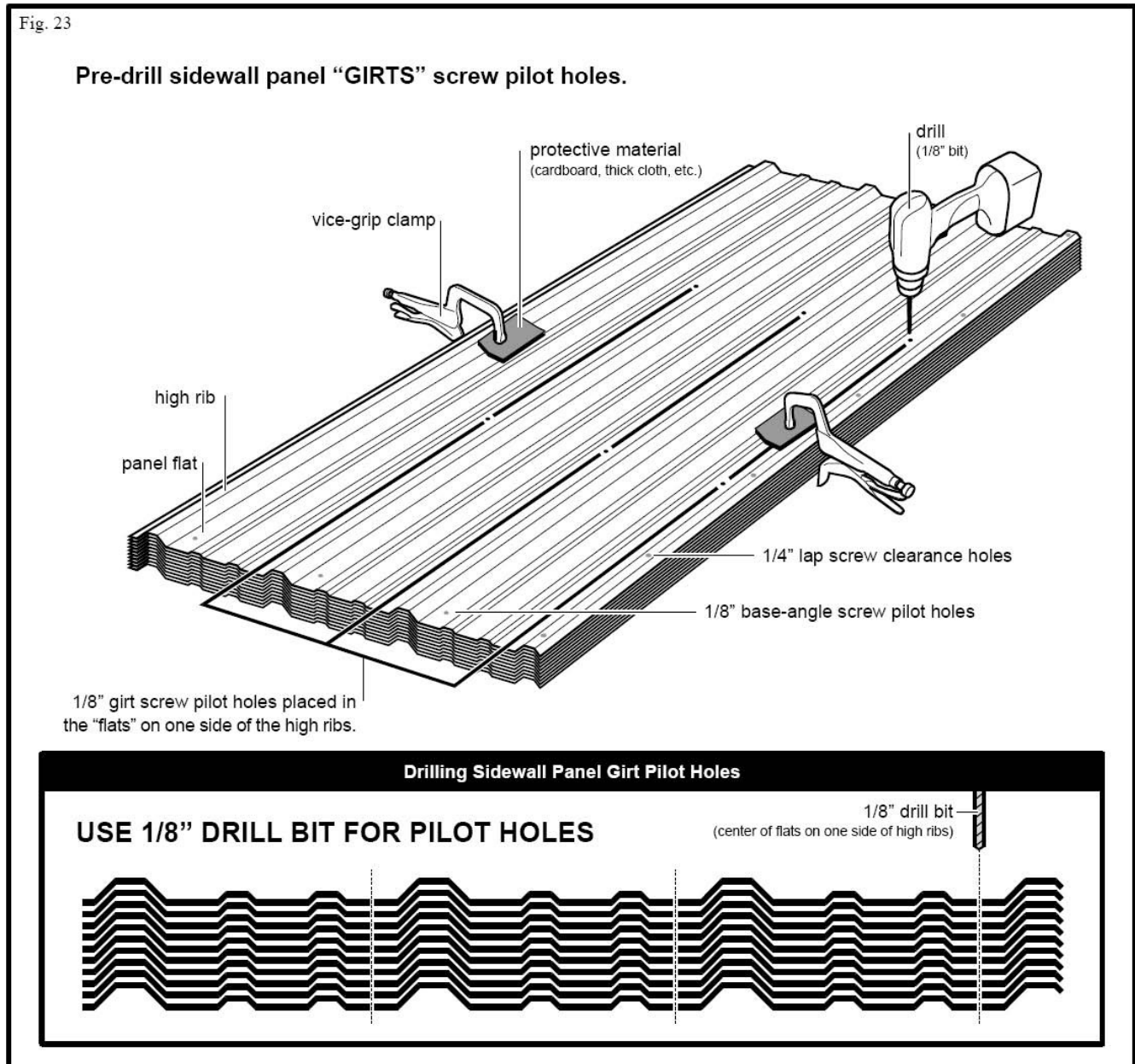

16.6. Prepare to pre-drill the “sidewall” eave strut pilot holes. (Figure 24)

Eave-Strut Detail Tip: Evenly aligned and distributed panel screws will yield a professional appearance. Drill the 1/8” eave strut screw pilot holes, according to the diagram below, or as specified by the erection drawings. For cosmetic reasons, place the pilot holes in the center of the panel “flats”.

16.6.1 (Refer to the illustration for “sidewall” eave strut screw pilot hole placement) Using a writing utensil and measuring tape, mark the first hole 1” from the top edge of the panel, in the center of the “flat” next to the high ribs.

16.6.2 Distribute the remaining pilot holes according to the diagram below.

16.6.3 Using a 1/8” drill bit, carefully drill holes through the panel stacks at the marked locations.

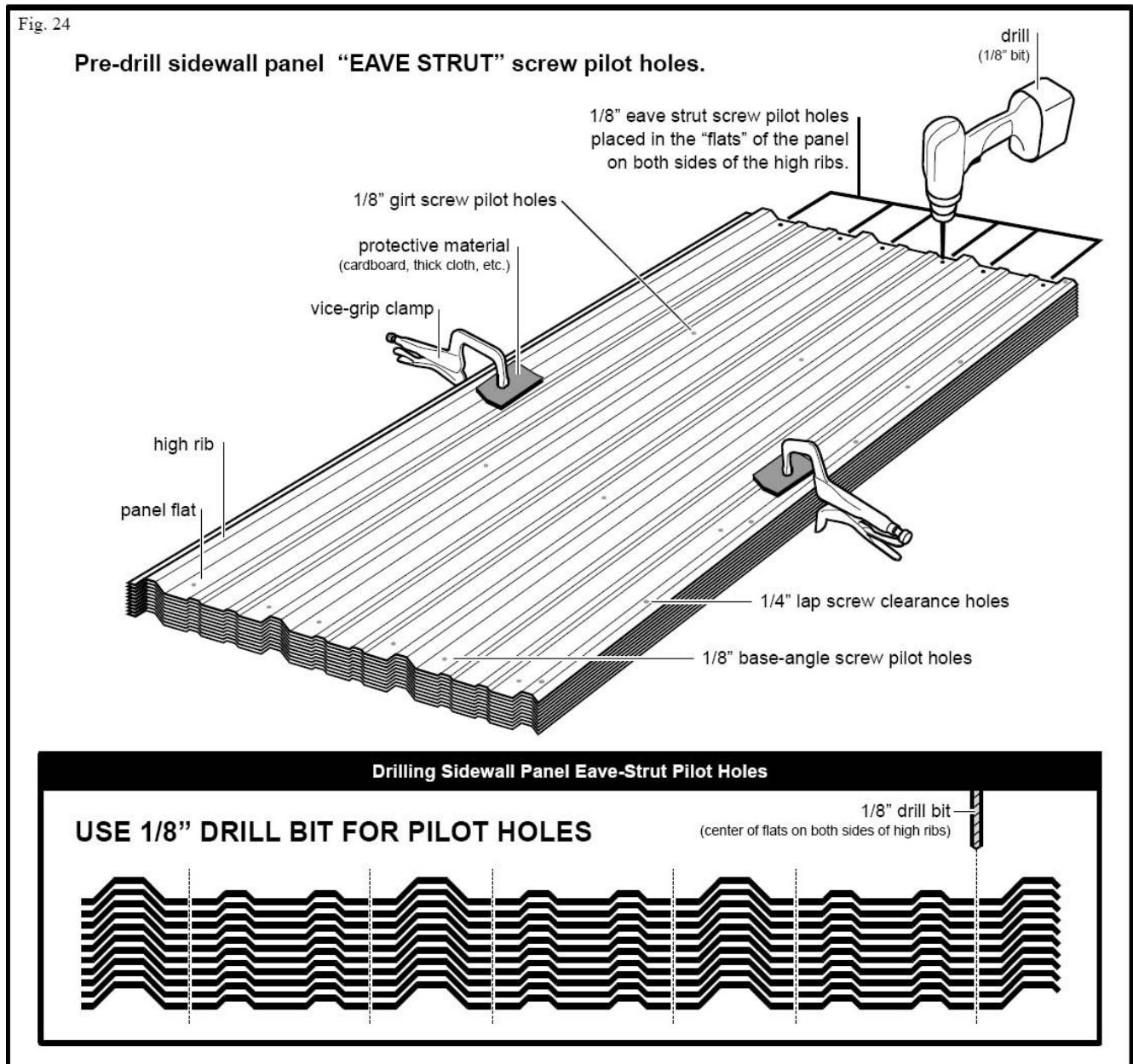

SIDEWALL INSULATION AND PANEL INSTALLATION

17. Prepare to install the “starting sidewall panel”.

17.1 If applicable, prepare to install insulation at this time. (This procedure pertains to the following insulation types.)

Reinforced Vinyl Backed Roll Insulation: This type of insulation is the most common insulation used in pre-engineered steel buildings; with one side having dense fiberglass mat which seats against the wall panels, and the vinyl vapor barrier exposed.

Foil Backed Roll Insulation: This type of insulation is also used in pre-engineered steel buildings; with one side having a craft paper backing which faces against the wall panels, and the foil heat barrier exposed.

17.2. To confirm the insulation is cut to the proper length, measure the area (s) to be insulated. (Figure 25)

17.2.1. Using a measuring tape, measure from the bottom of the base angle to the top of the eave strut.

17.3. Roll out the “Sidewall Insulation Roll”, then cut the insulation to length as per the manufacturer cut instruction sheet. The length of insulation must be approximately 4” to 6” longer than the area to be covered.

Important: The insulation must be compressed between the girt and the wall panel. Very thick or dense insulation will not compress adequately resulting in waviness in certain types of wall panels.

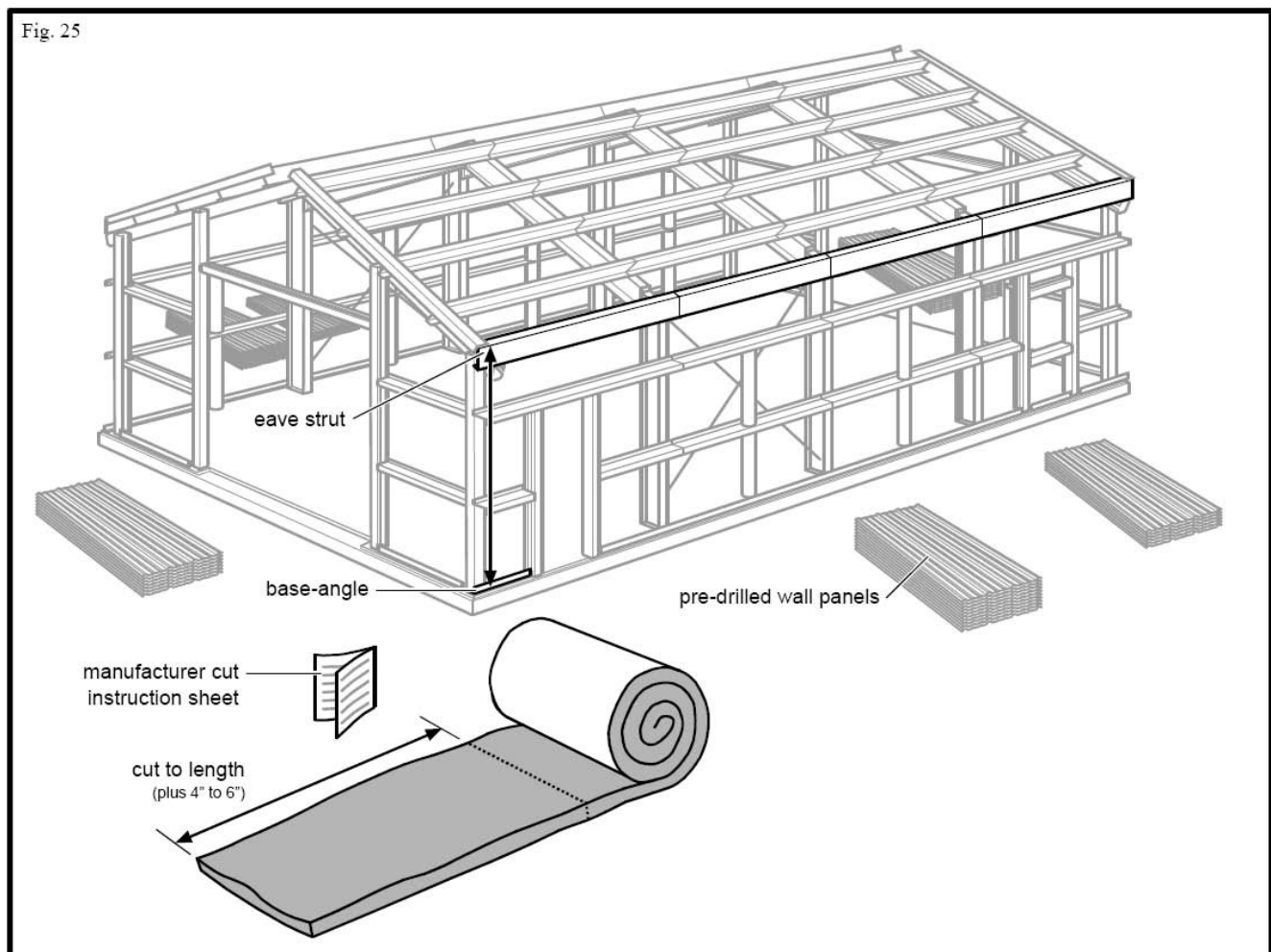

17.4. Install the “starting” row of insulation. (Figure 26)

17.4.1. Place strips of double-side tape, approximately 7 ft. in length, along the eave strut, base-angle, and around any framed openings.

17.4.2. Attach the row of insulation to the eave strut and base-angle.

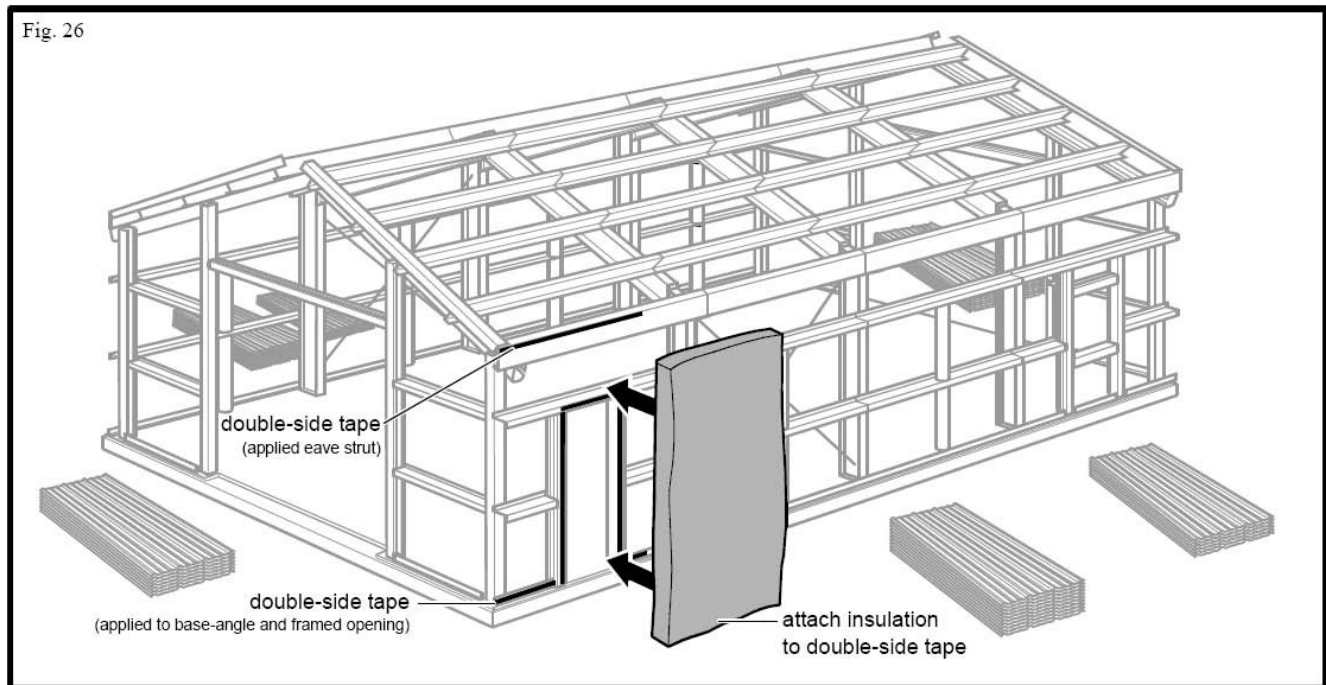
**17.5.** Trim the insulation for wall panel installation. (Figure 27)

17.5.1. Using a utility knife, without cutting through the vinyl backing, trim the “insulation” even with the bottom of the base angle and the top of the eave strut.

17.5.1. Trim the vinyl backing off about 2” to 4” past the insulation, leaving a flap to fold back protecting the insulation from weather.

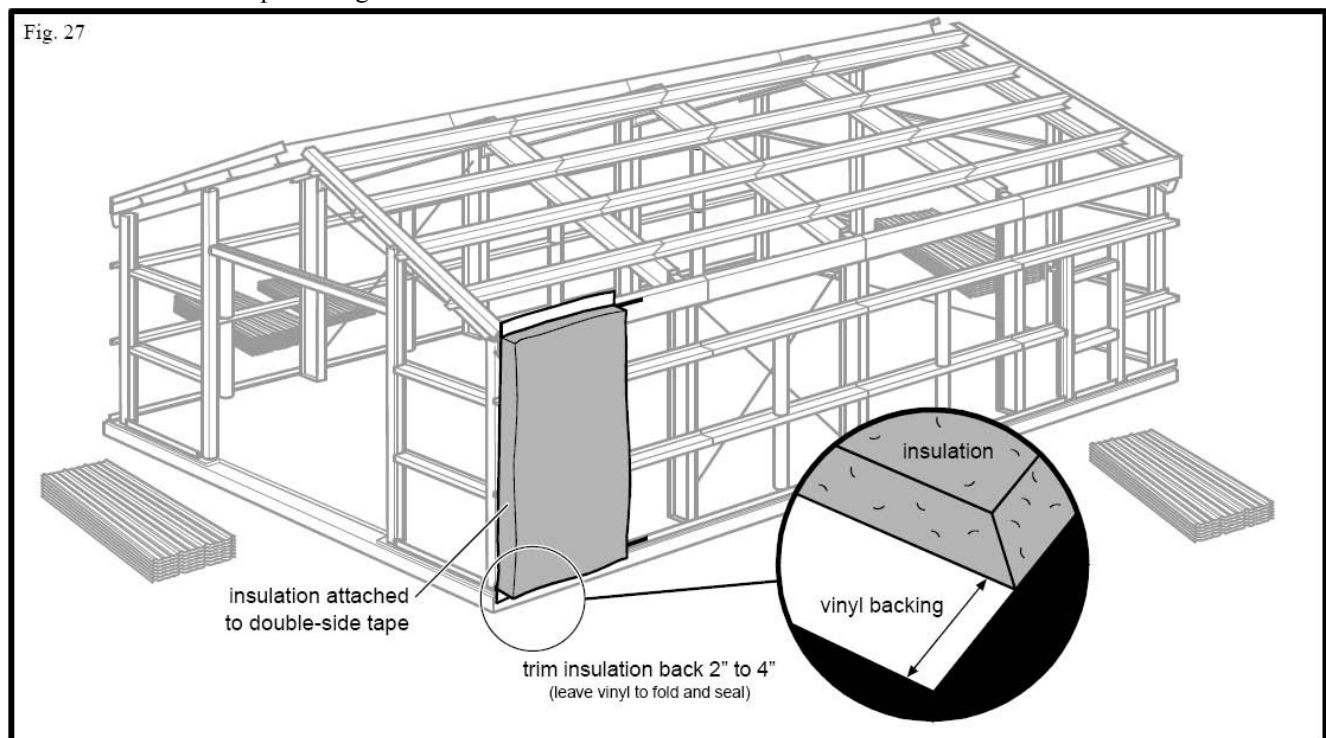

17.6 Trim the insulation for a framed opening. (Figure 28)

17.6.1. Using a utility knife, without cutting through vinyl backing, remove the insulation from the area of the framed opening.

17.6.2. Using a utility knife, cut an “X” from corner to corner.

17.6.3. To protect the insulation from weather, fold the flaps back as necessary.

Important: Do not allow the insulation to wick moisture from the floor!

Safety Precaution: Insulation has no load bearing strength. Do not lean or prop material against wall insulation.

Observe all safety procedures when handling fiberglass insulation, such as dust masks, gloves and long sleeved shirts to minimize contact with the insulation fibers.

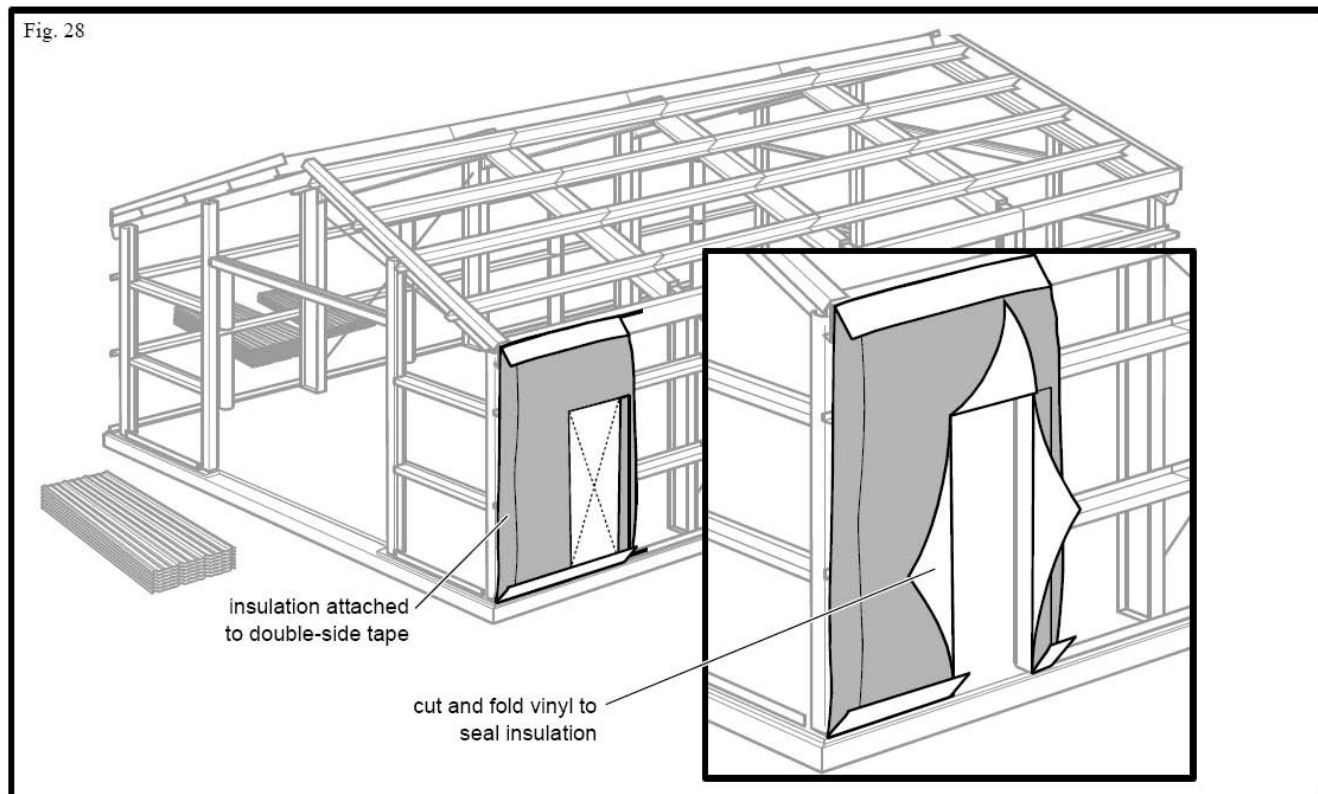

Proper Screw Installation (Figure 29)

Panel-to-Panel/Panel-to-Trim Notice: To secure panel-to-panel/panel-to-trim locations and prevent leaking, use #12 x 7/8” S.D.S. self-tapping screws with sealing washers.

Panel-to-Structure Notice: To secure panel-to-structure locations and prevent leaking, use #12 x 1-1/4” S.D.S. self-tapping screws with sealing washers.

Important: Use screws with sealing washers only. Ensure proper sealing by installing all screws perpendicular to the panel surface at just the right tension.

Notice: Occasionally, the rubber seal will spin out from under the screw. Replace the seal as necessary.

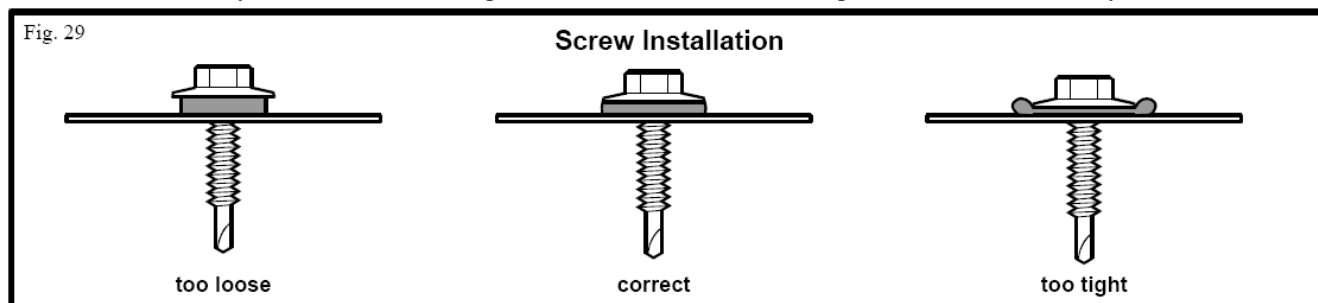

17.7. Starting at a sidewall corner, place-fit the panel to confirm it is the proper length.

Important: For trouble free corner trim installation, proper sidewall panel alignment is crucial.

Notice: If insulation is being installed, insulation should be visible out past the high lap rib.

17.7.1 The top of the panel must not extend over the eave strut.

17.8. Holding the panel plumb, with the center of the first panel high rib aligned to the edge of the framing, use #12 x 1 1/4" self-tapping screw with sealing washers to secure the sidewall panel. (Figure 30)

17.8.1. The pre-drilled pilot holes shall align the #12 x 1-1/4" self-tapping screws in the center of the girts, on approximately 12" centers.

17.8.2. The pre-drilled pilot holes shall align the #12 x 1-1/4" self-tapping screws in the center of the base-angle and eave strut.

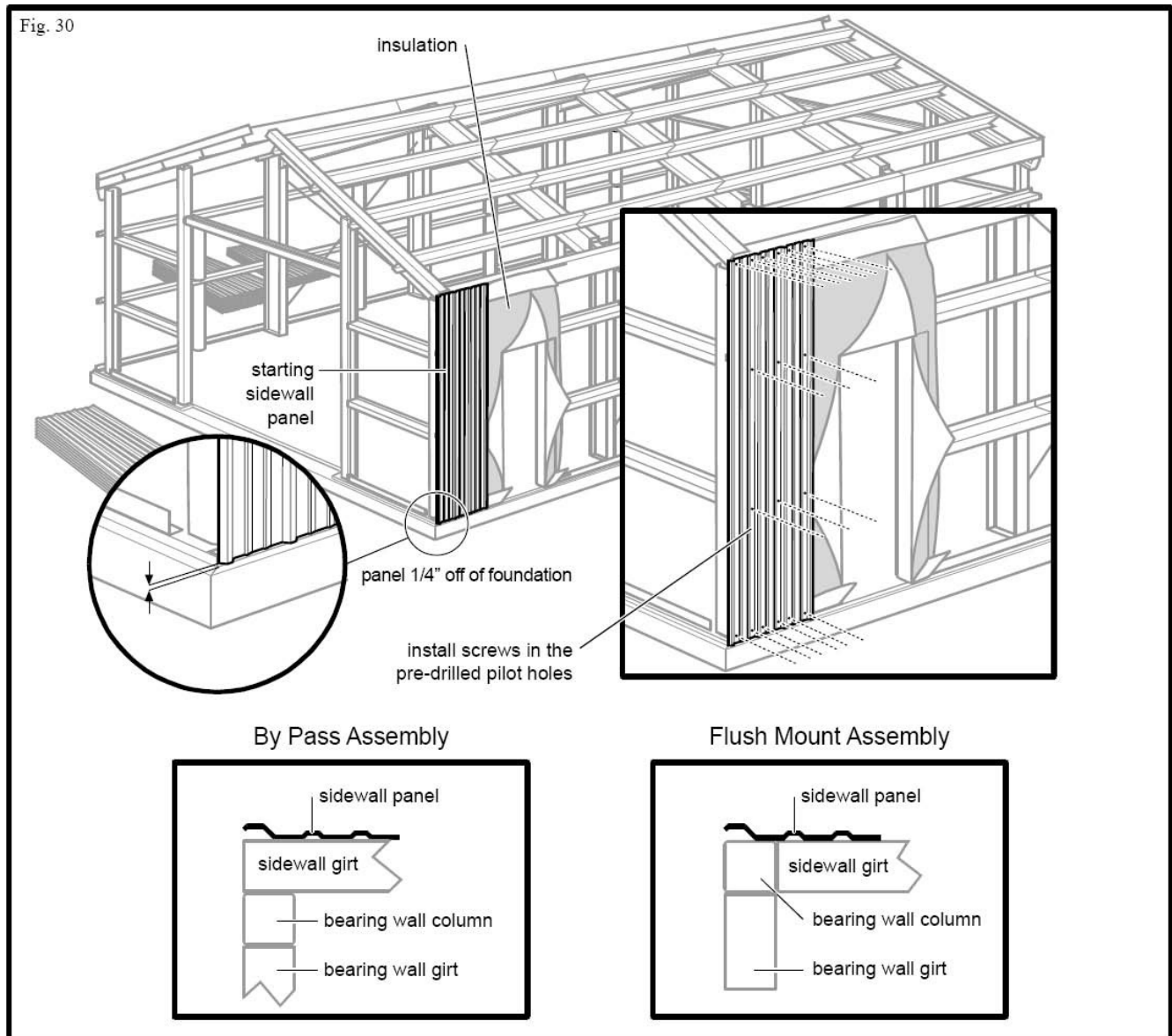

18.2. Install a row of insulation. (Figure 32)

18.2.1 Place strips of double-sided tape, approximately 7 ft. in length, along the eave strut and base-angle.

18.2.2. Attach the row of insulation to the eave strut and base-angle.

18.2.3. Using a utility knife, without cutting through the vinyl backing, trim the “insulation” even with the bottom of the base-angle and the top of the eave strut.

18.2.4. Trim the vinyl backing off about 2” to 4” past the insulation, leaving a flap to fold back protecting the insulation from weather.

Important: Do not allow the insulation to wick moisture from the floor.

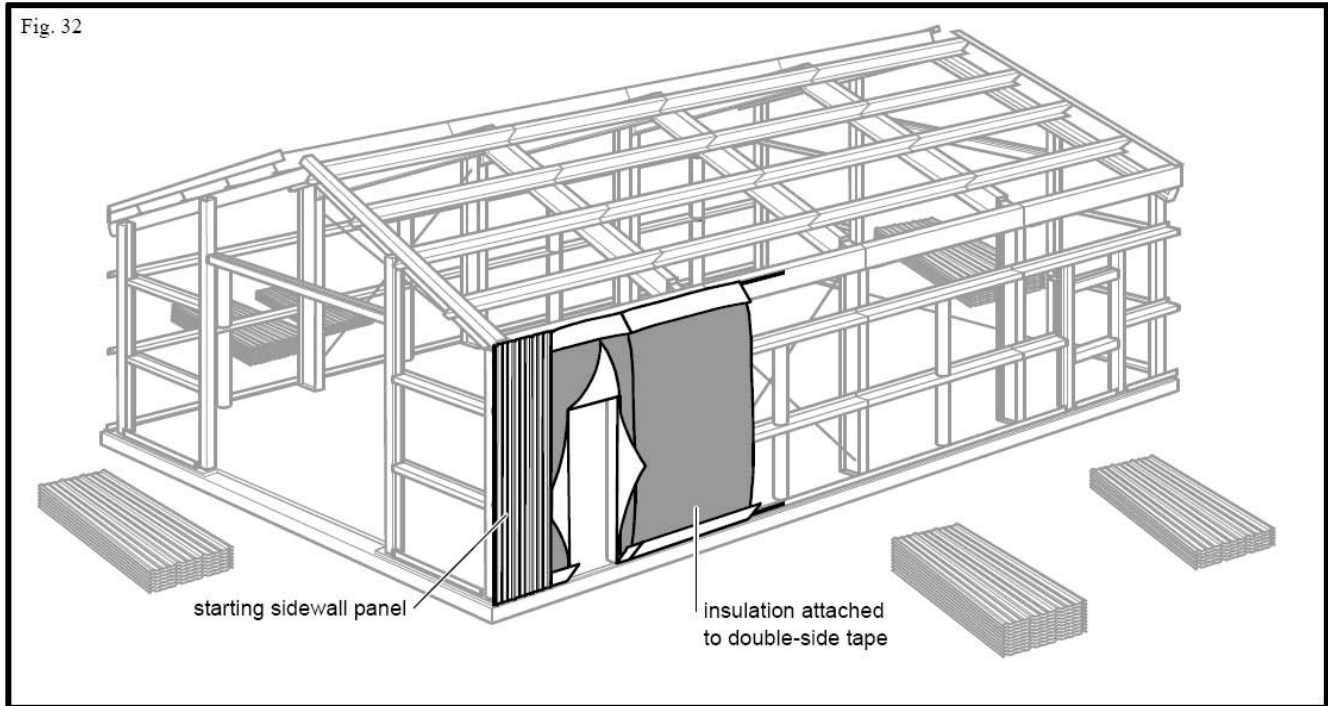

18.3. Lap the outer rib over the preceding panel; hold it plumb then secure as necessary. (Figure 33)

18.3.1. The pre-drilled pilot holes shall align the #12x 1 1/4 "self-tapping screws in the center of the girts, on approximately 12" centers.

18.3.2. The pre-drilled pilot holes shall align the #12 x 1 1/4" self tapping screws in the center of the base-angle and eave strut, on approximately 6" centers.

18.3.3. Using #12 x 7/8" self- tapping screws with sealing washers, stitch the lapping ribs together on approximately 30" centers.

18.4. Repeat steps 24 until the sidewall is complete.

18.4.1. Backlapping the panels 1 or 2 feet are routinely done to match panel coverage to building width. This is done with the last panel installed on the sidewall and endwall.

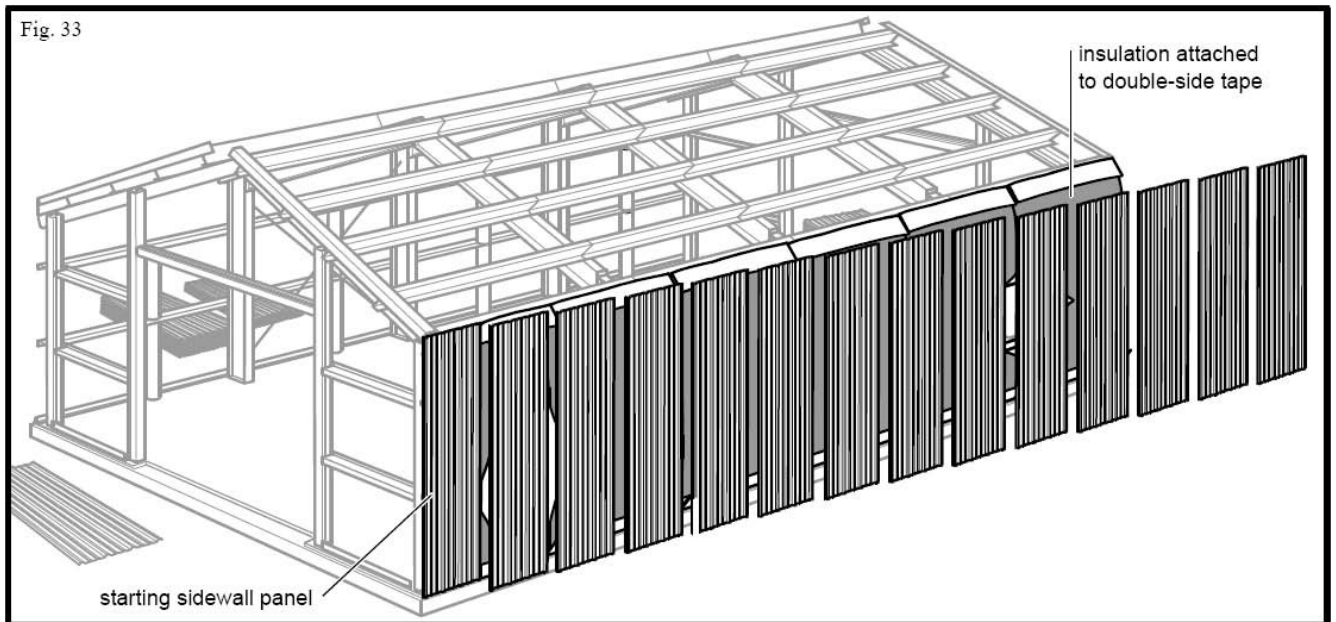

18.6 Remove all wooden girt supports. Refer to page 40.

PRE-DRILL ENDWALL PANELS

19. Prepare to pre-drill “endwall” panels for easy installation.

19.1 Due to the manufacturing process, oil may have been applied to protect panels. Prior to installation, use a clean rag and an approved cleaner to wipe panels free of foreign debris and residue.

Safety Precaution: Wear OSHA approved eye protection when operating drill. Electric tools must be properly grounded. Do not use electrical equipment while standing on wet surfaces.

Warning: Reverse rolled panels require different screw patterns. Refer to the construction drawings for proper screw placement.

Lap Screw Detail Tip: Evenly aligned and distributed panel screws will yield a professional appearance. Drill the 1/8” lap screw clearance holes down the center of the high lap rib on 30” centers or as specified by the erection drawings (drill the first hole 2 1/2” from the bottom edge then distribute as necessary). For cosmetic reasons, place the lap screw clearance holes in the center of the panel’s high lap rib.

19.2 To confirm the proper panels are being pre-drilled, measure the area (s) to be covered. (Figure 35)

19.2.1. Separate and neatly stack all endwall panels into groups of like lengths.

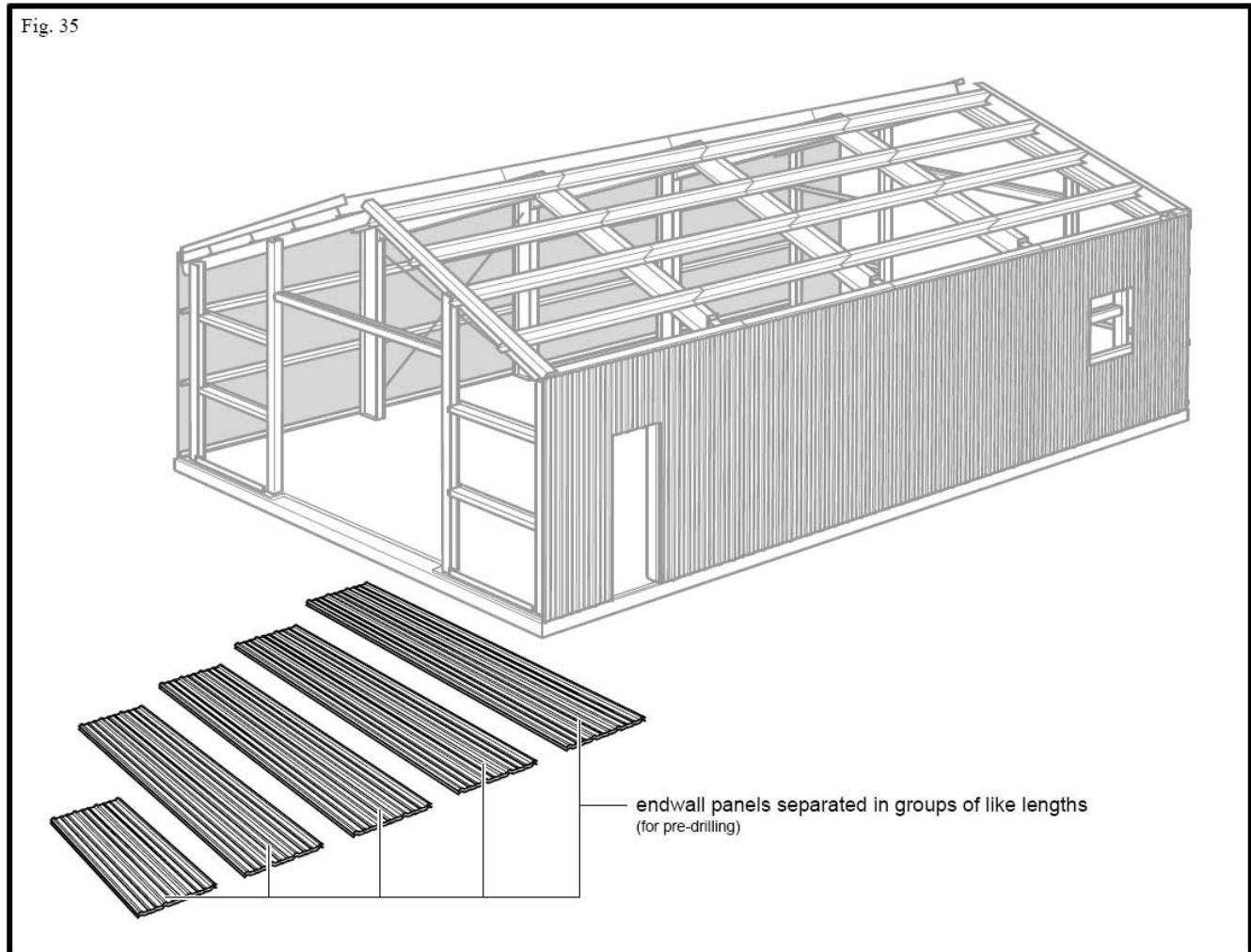

19.3 Prepare to pre-drill the “endwall” lap screw clearance holes. (Figure 36)

19.3.1. With the panels pre-arranged in stacks of like lengths and perfectly aligned, using vice-grip clamps to secure the stack in preparation for drilling. This will help prevent misalignment.

19.3.2. (Refer to the illustration for “endwall” lap screw clearance hole placement.) Using a writing utensil and measuring tape, mark the first hole location 2 ½” from the bottom of the panel lap rib then distribute the remaining clearance holes on 30” centers or as specified by the erection drawings.

19.3.3. Using a 1/8” drill bit, carefully drill holes through the panel stacks at the marked locations.

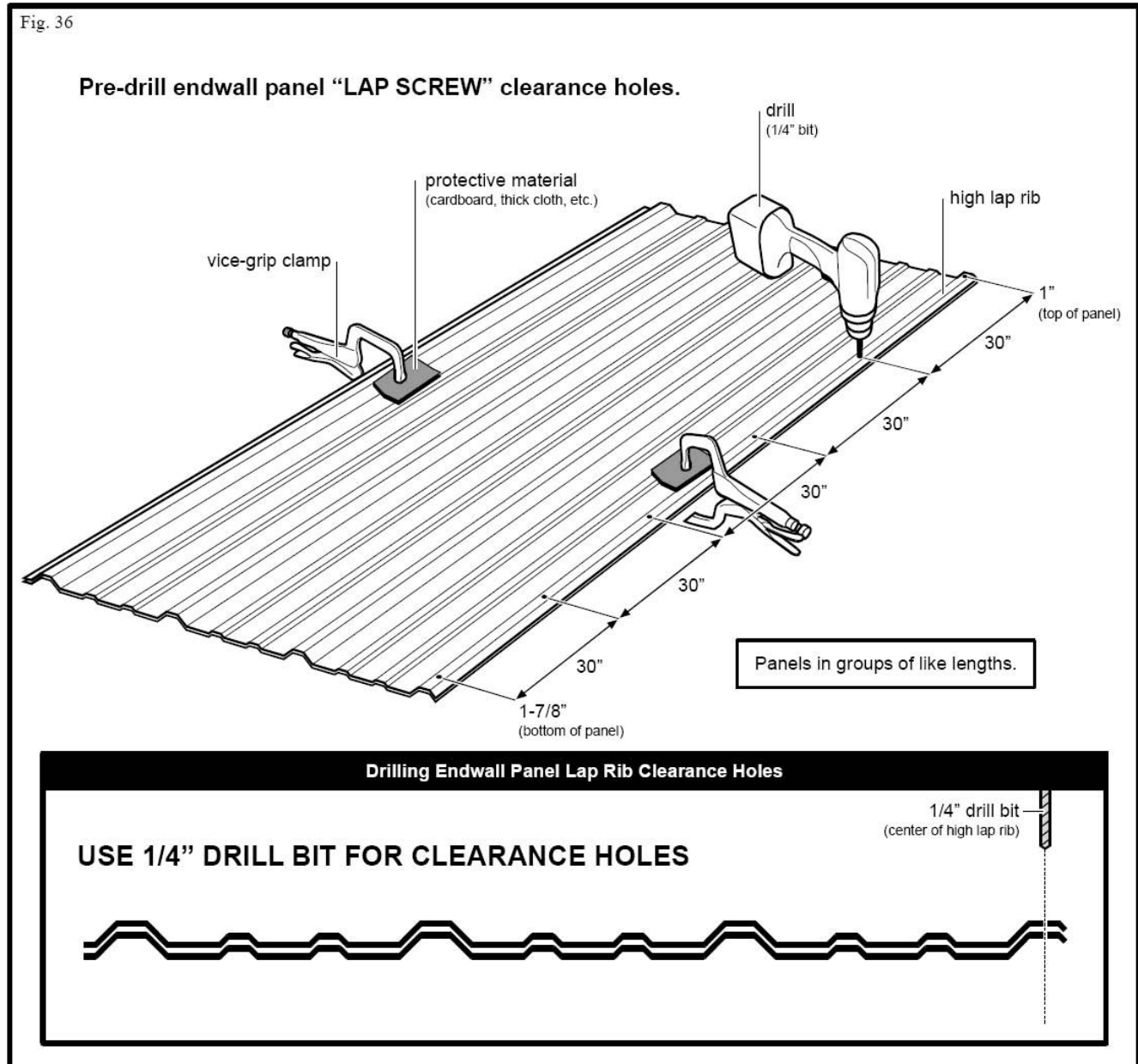

19.4 Prepare to pre-drill the “endwall” base-angle/header pilot holes. (Figure 37)

Base-Angle/Header Detail Tip: Evenly aligned and distributed panel screws will yield a professional appearance. Drill the 1/8” base-angle/header screw pilot holes according to diagram below, or as specified by the erection drawings. For cosmetic reasons, place the pilot holes in the center of the panel “flats”.

19.4.1. (Refer to the illustration for the “endwall” base angle screw pilot hole placement.) Using a writing utensil and measuring tape, mark the first hole 2 1/2 “ from the bottom edge of the panel, in the center of the “flat” next to the high ribs.

19.4.2. Distribute the remaining pilot holes according to diagram below, or as specified by the erection drawings.

19.4.3. Using a 1/8” drill bit, carefully drill holes through the panel stacks at the marked locations.

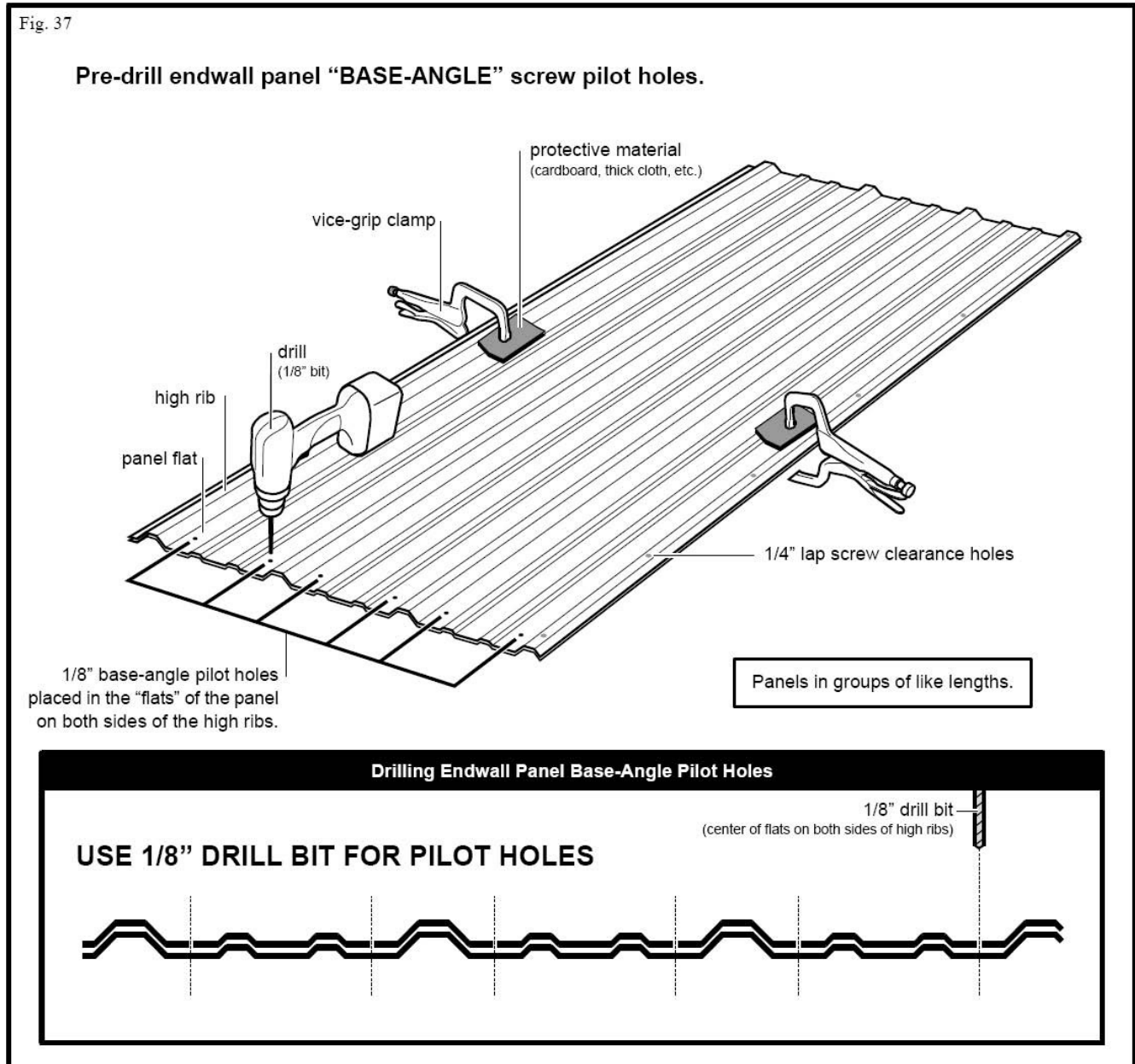

19.5 Prepare to pre-drill the “endwall” girt screw pilot holes. (Figure 38)

Girt Screw Detail Tip: Evenly aligned and distributed panel screws will yield a professional appearance. Drill the 1/8” girt screw pilot holes according to diagram below, or as specified by the erection drawings. For cosmetic reasons, place the girt screw pilot holes in the center of the panel “flats”.

19.5.1. Using a measuring tape, measure from the base-angle to the center of the girt line(s).

19.5.2. (Refer to the illustration for “endwall” girt screw pilot hole placement.) Using a writing utensil and measuring tape, mark the first hole(s) next to the lap rib in the center of the flat as shown then distribute the remaining pilot holes on approximately 12” center or as specified by the erection drawings .

19.5.3. Using a 1/8” drill bit, carefully drill holes through the panel stacks at the marked locations.

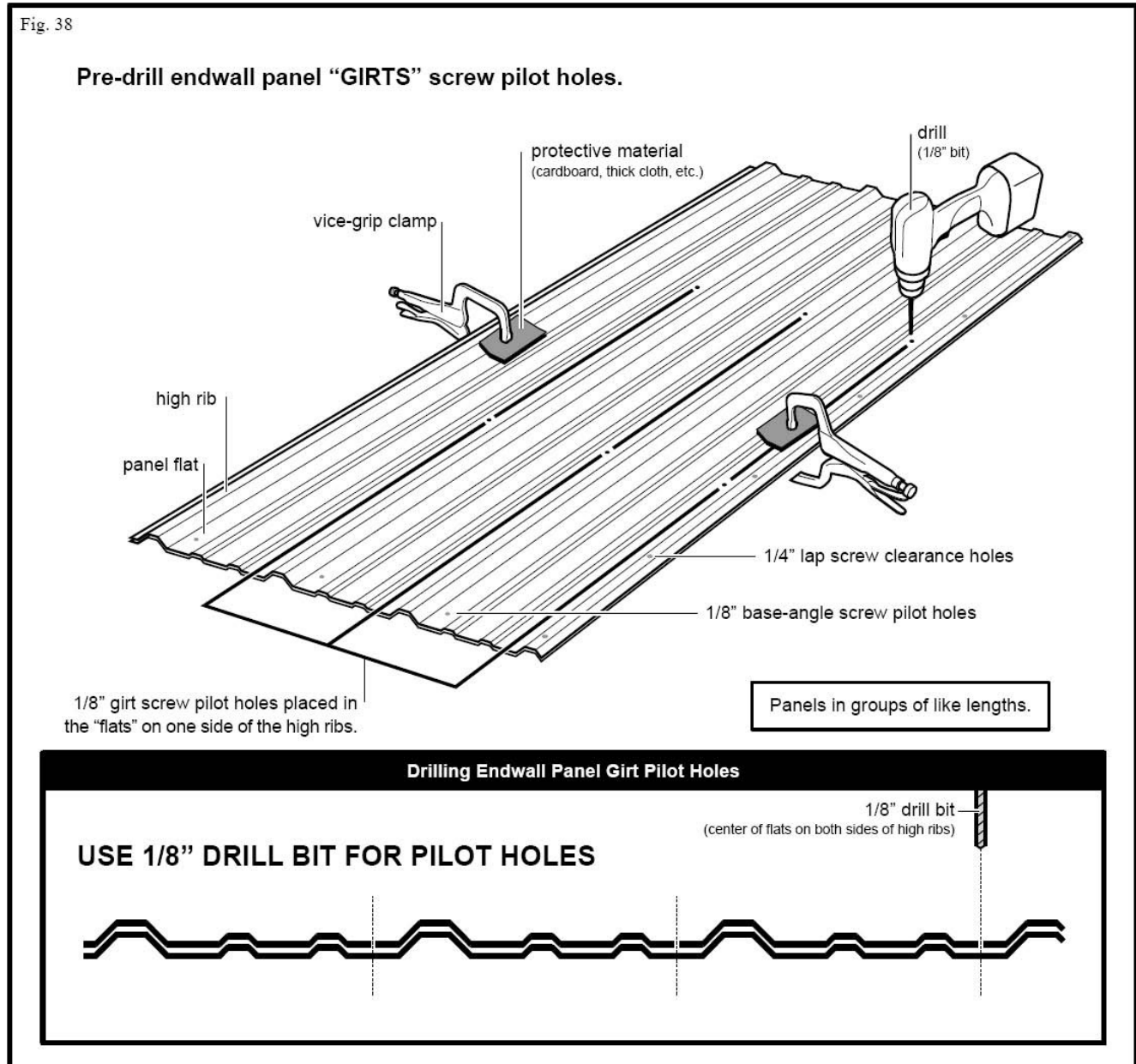

ENDWALL INSULATION AND PANEL INSTALLATION

20. Prepare to install the first “endwall” panel.

20.1 If applicable; prepare to install insulation at this time. **(This procedure pertains to the following insulation types)**

Reinforced Vinyl Backed Roll Insulation: This type insulation is the most common insulation used in pre-engineered steel buildings; with one side having dense fiberglass mat which seats against the wall panels, and the vinyl vapor barrier exposed.

Foil Backed Roll Insulation: This type of insulation is also used in pre-engineered steel buildings; with one side having a craft paper backing which faces against the wall panels and the foil heat barrier exposed.

20.2. To confirm the insulation is cut to the proper length, measure the area (s) to be insulated. (Figure 39)

24.2.1. Using a measuring tape, measure from the bottom of the base-angle to the top of the rake angle.

20.3. Roll out the “Endwall Insulation Roll”, and then cut the insulation to length as per the manufacturer cut instruction sheet. The length of insulation must be approximately 4” to 6” longer than the area to be covered.

Important: The insulation must be compressed between the girt and the wall panel. Very thick or dense insulation will not compress adequately resulting in waviness in certain types of wall panels.

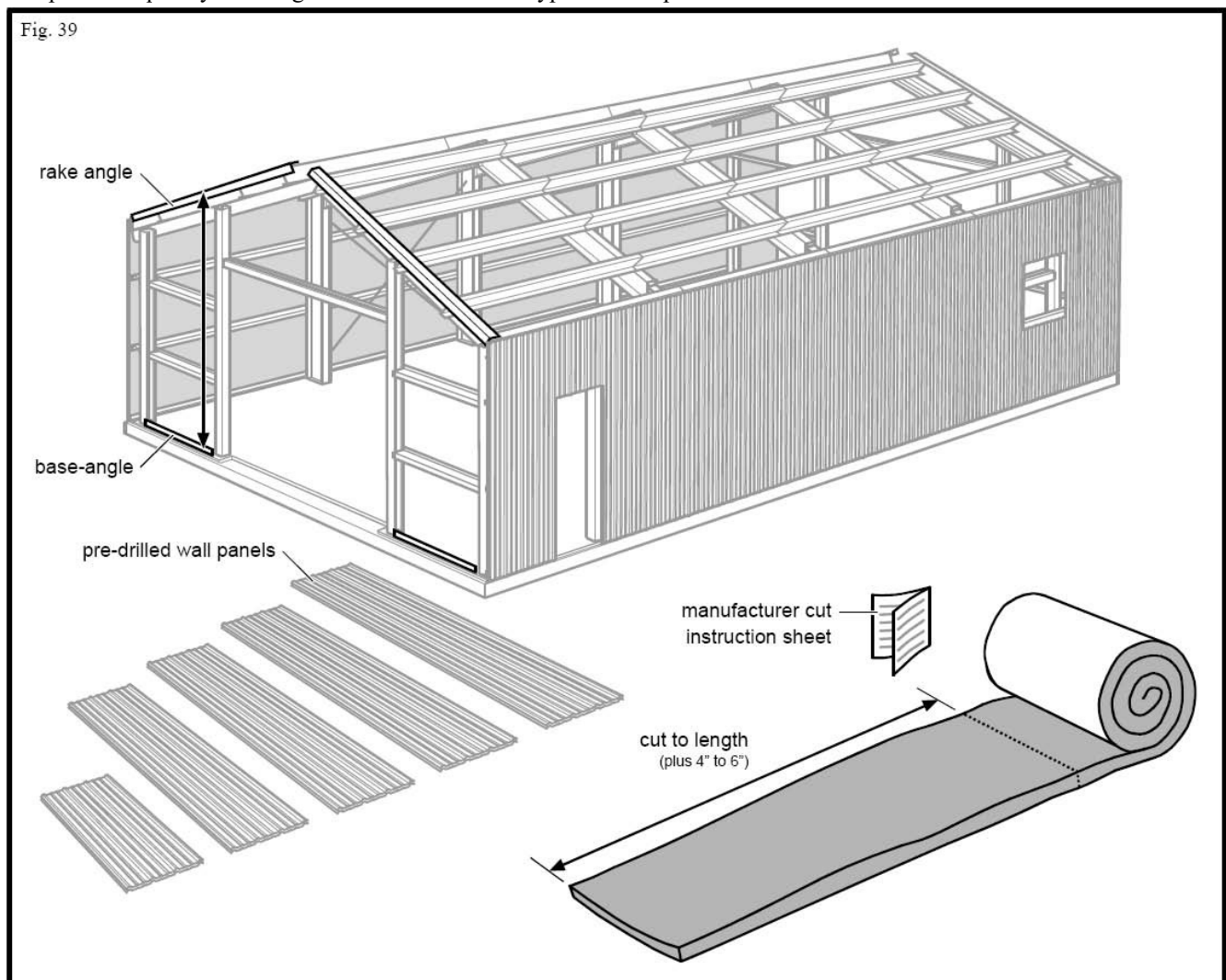

20.4. Install the “starting” row of insulation. (Figure 40)

20.4.1 Place strips of double sided-tape, approximately 6 ft. in length, along the rake-angle and base-angle.

20.4.2. Attach the insulation to the rake-angle and base-angle.

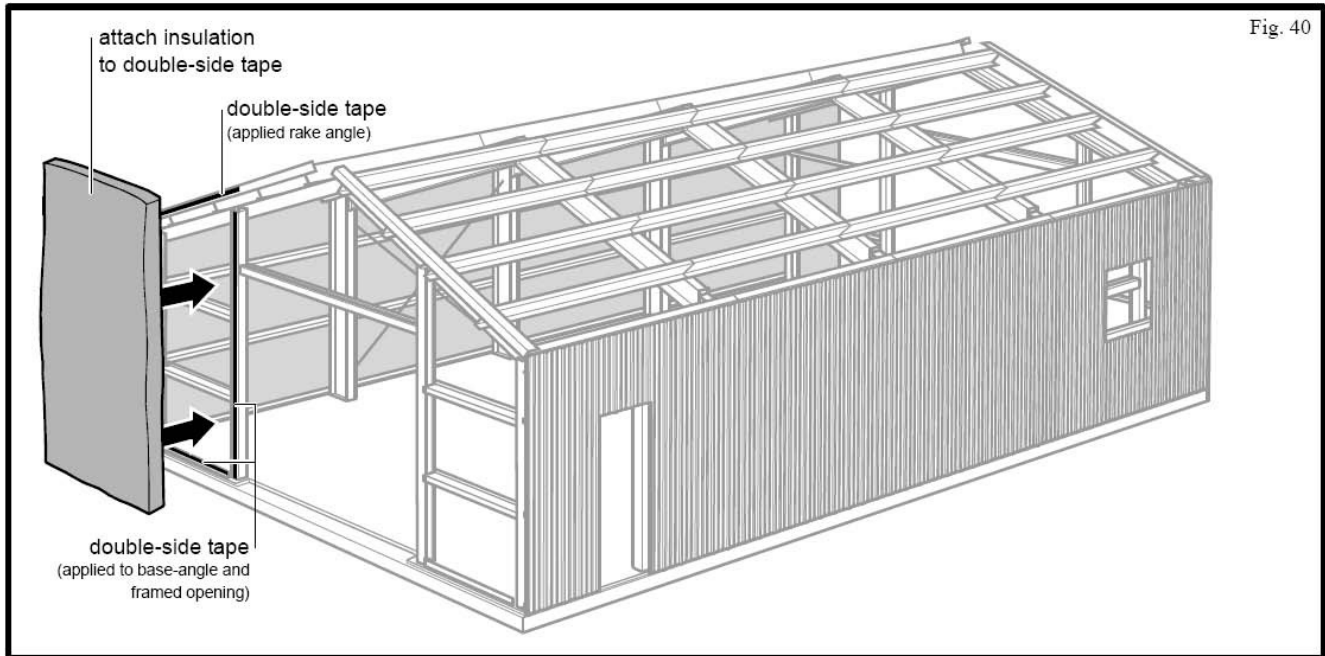

20.5. Trim the insulation for wall panel insulation. (Figure 41)

20.5.1. Using a utility knife, **without cutting through the vinyl backing**, trim the “insulation” even with the bottom of the base angle and the top of the rake-angle.

20.5.2 Trim the vinyl backing off about 2” to 4” past the insulation, aligned with the rake angle, leaving a flap to fold back protecting the insulation from the weather.

Important: Do not allow the insulation to wick moisture from the floor!

Safety Precaution: Insulation has no load bearing strength. Do not lean or prop material against wall insulation. Observe all proper safety procedures when handling fiberglass insulation, such as dust masks, gloves, and long sleeved shirts, to minimize contact with the insulation fibers.

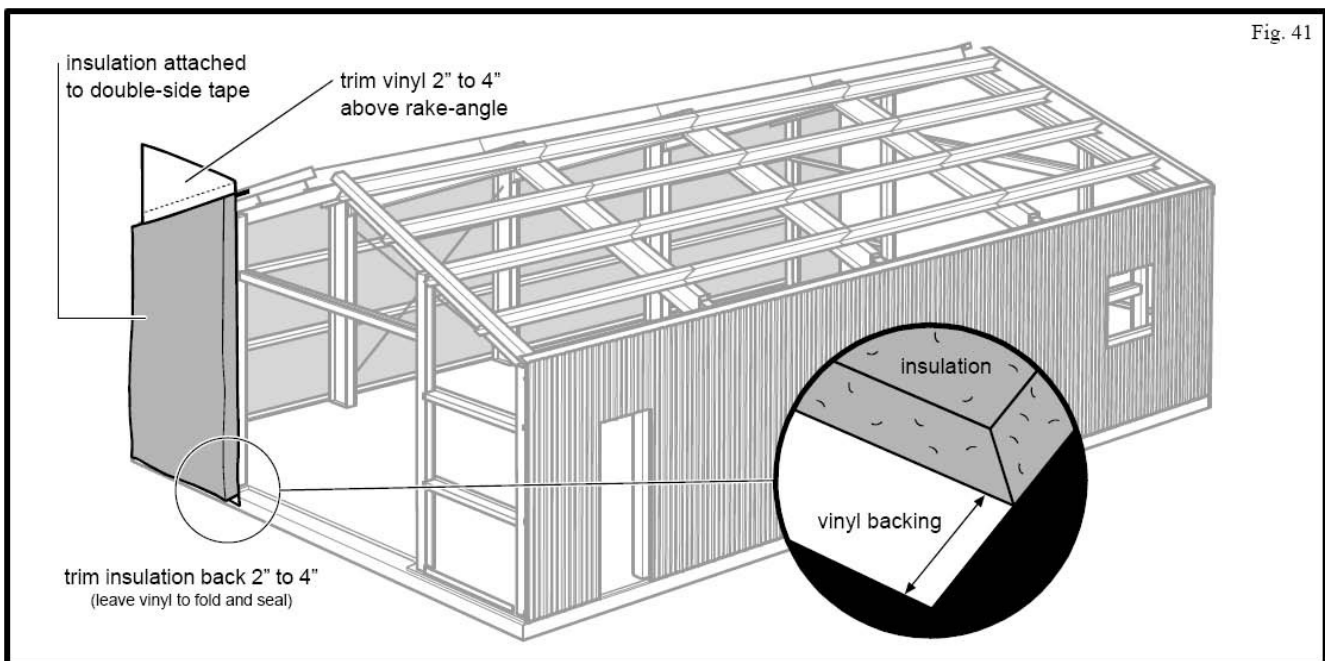

20.6 Starting at an endwall corner, place-fit the panel to confirm it is the proper length.

Notice: If insulated is being installed, approximately 1 ft of the insulation should be visible out past the high lap rib.

Important: If a panel appears too long or short, confirm the correct panel is being installed. Trimming is required for endwall panels is used on buildings that have a roof pitch of 2;12 or greater.

20.7 Holding the panel plumb, align the center of the first panel high panel rib to the edge of the framing. (Figure 42)

20.7.1. The pre-drilled pilot holes shall align the #12 x 1-1/4" self-tapping screws in the center of the girts, on approximately 12" centers.

20.7.2. The pre-drilled pilot holes shall align the #12 x 1-1/4" self-tapping screws in the center of the base-angle.

Note: The endwall panels should be secured to the rake-angle after all base-angle and girts screws are installed.

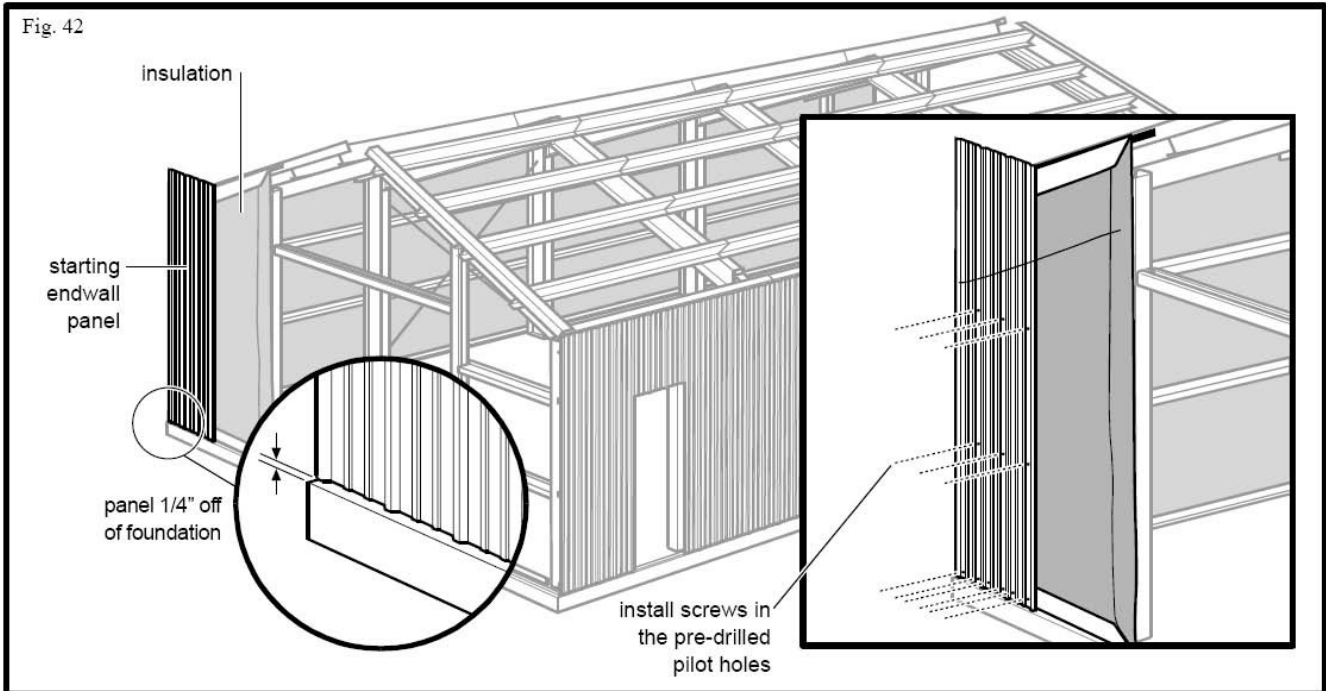

Endwall Panel Positioning

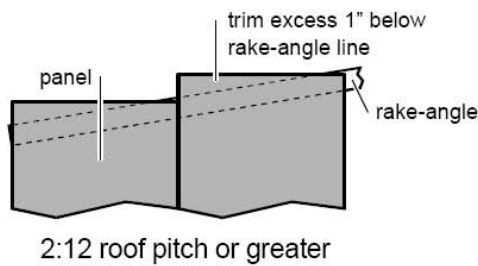
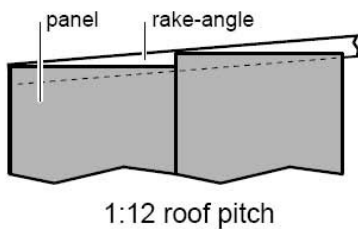

By Pass Assembly

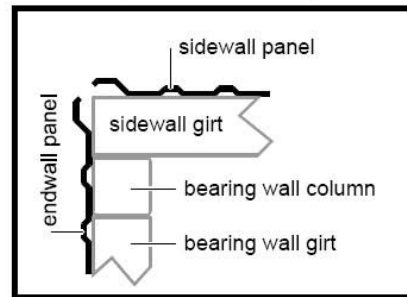

Tip: To avoid the screws in the rake angle from being visible, after the rake-angle is installed, place the screws as close to the top edge of the endwall panel as possible.

20.8 Secure the top of the endwall panels to the rake-angle as necessary, by installing the screws on approximately 6" centers, in the center of the "flat" next to the high ribs. (Figure 43)

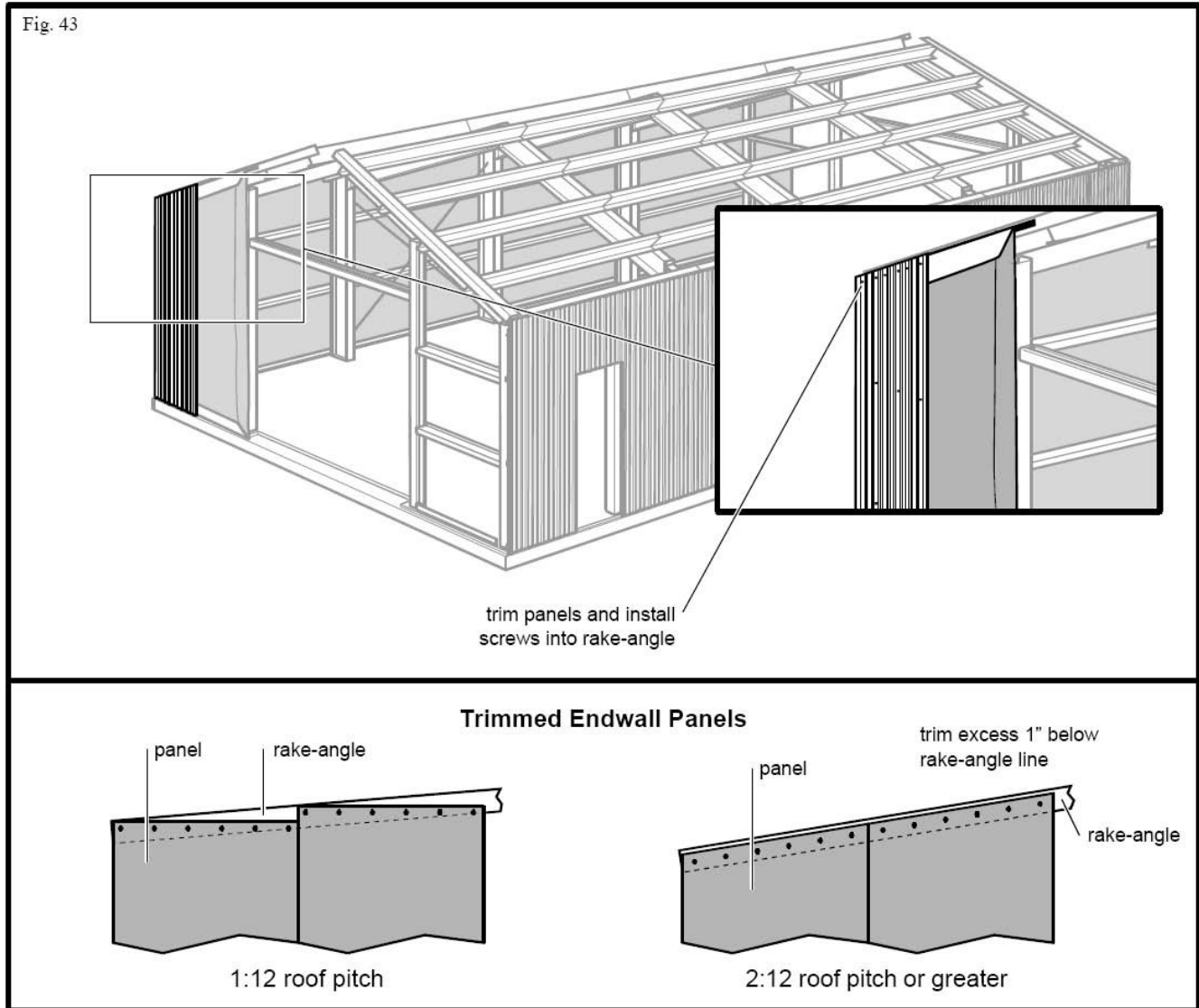

21. To complete the endwall, prepare to install the remaining panels.

Notice: Sealant tape is not used on endwall panel installations.

Warning: Do not use lap screws for securing wall panels to the girts.

21.1. Install a row of insulation. (Figure 44)

21.1.2. Attach the row of insulation to the rake-angle and base-angle.

21.1.3. Using a utility knife, without cutting through the vinyl backing, trim the “insulation” even with the bottom of the base-angle and the top of the rake-angle.

21.1.4. Trim the vinyl backing off about 2” to 4” past the insulation, aligned with the rake-angle, leaving a flap to fold back protecting the insulation from weather.

Important: Do not allow the insulation to wick moisture from the floor!

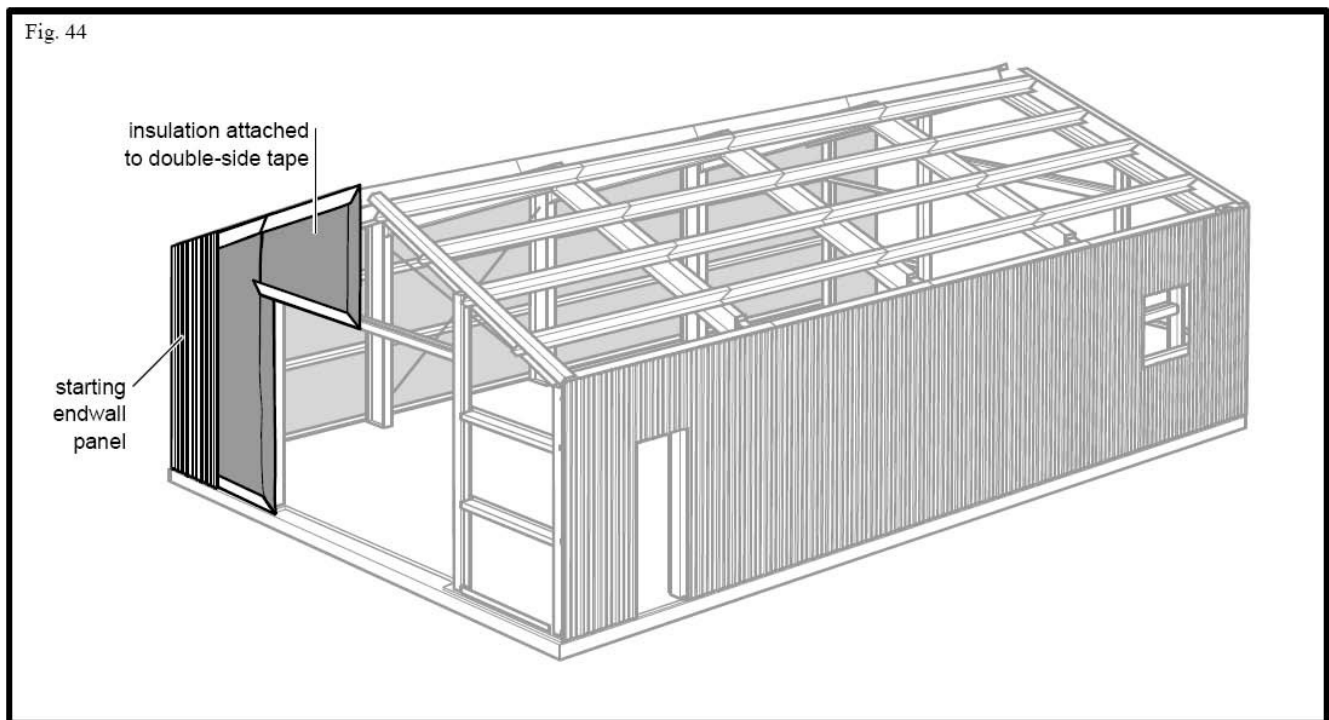

Notice: If insulation is being installed, approximately 1 ft. of the insulation should be visible out past the high lap rib.

Important: If panel appears too long or short, confirm the correct panel is being installed. Trimming is required for endwall panels used on buildings that have a roof pitch of 2:12 or greater.

21.2 Hold the panel and plumb and secure as necessary. The top of the panel must not extend over the rake-angle. (Figure 45)

21.2.1. The pre-drilled pilot holes shall align the #12 x 1-1/4" self-tapping screws in the center of the girts, on approximately 12" centers.

21.2.2. The pre-drilled pilot holes shall align the #12 x 1 ¼ self-tapping screws in the center of the base angle.

Note: The endwall panels shall be secured to the rake-angle after all base-angle and girts screws are installed.

21.2.3. Using #12 x 7/8" self-tapping screws with sealing washers, stitch the lapping ribs together on approximately 20" centers.

Tip: To avoid the screws in the rake angle from being visible, after the rake-trim is installed, place the screws as close to top edge of the edge of endwall panel as possible.

21.2.4. Secure the top of the endwall panels to the rake-angle as necessary, by installing the screws in the same location as the bottom of the panel.

21.3. Repeat step 25 until the endwall is complete.

21.4. Repeat steps 24 and 25 on the other endwall.

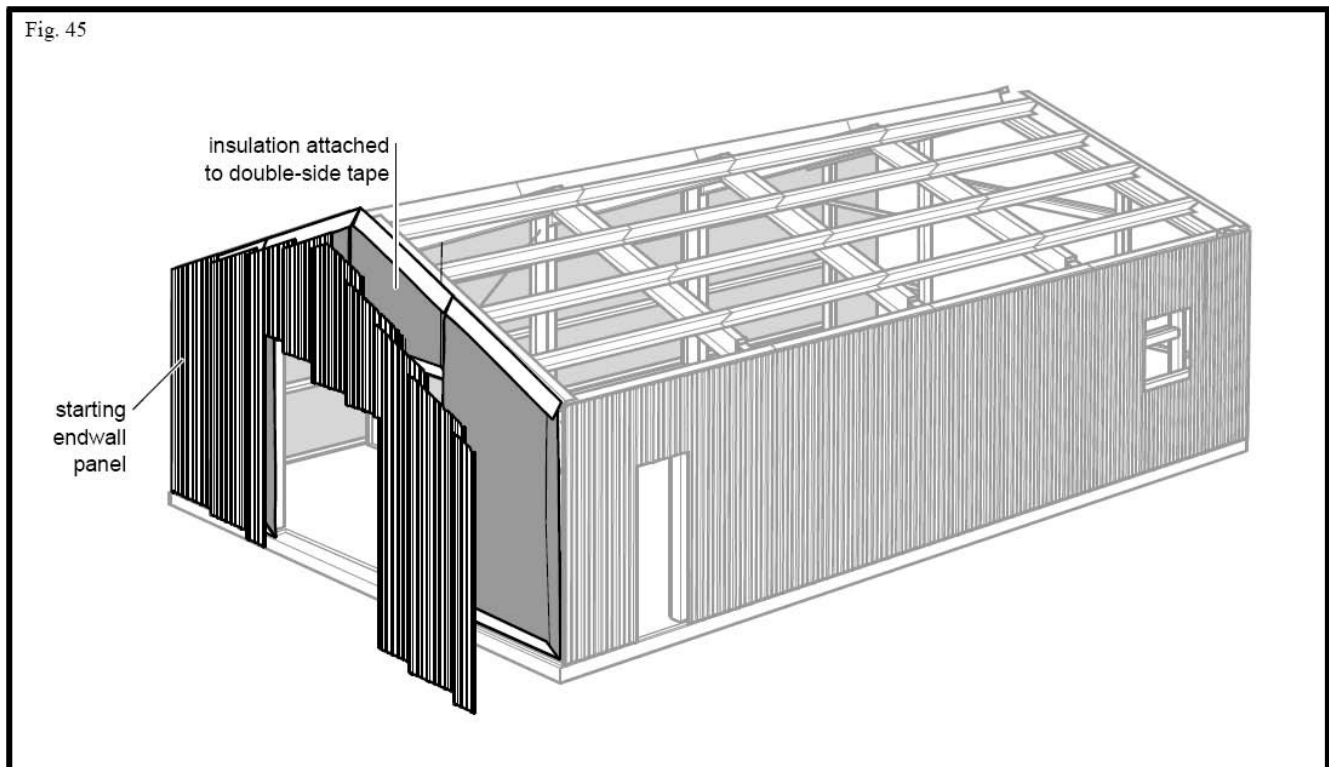

CORNER TRIM INSTALLATION

22. Prepare to install the corner trim. (Figure 46)

- 22.1. Place-fit the corner trim (should be about 1" from the top of the eave strut). Ensure length is correct.
- 22.2. Using #12 x 7/8" self-tapping screws, attach the corner trim to the sidewall and endwall panels. Place the screws on approximately 20" centers.
- 22.3. Repeat step 26 on the remaining corners of the building.

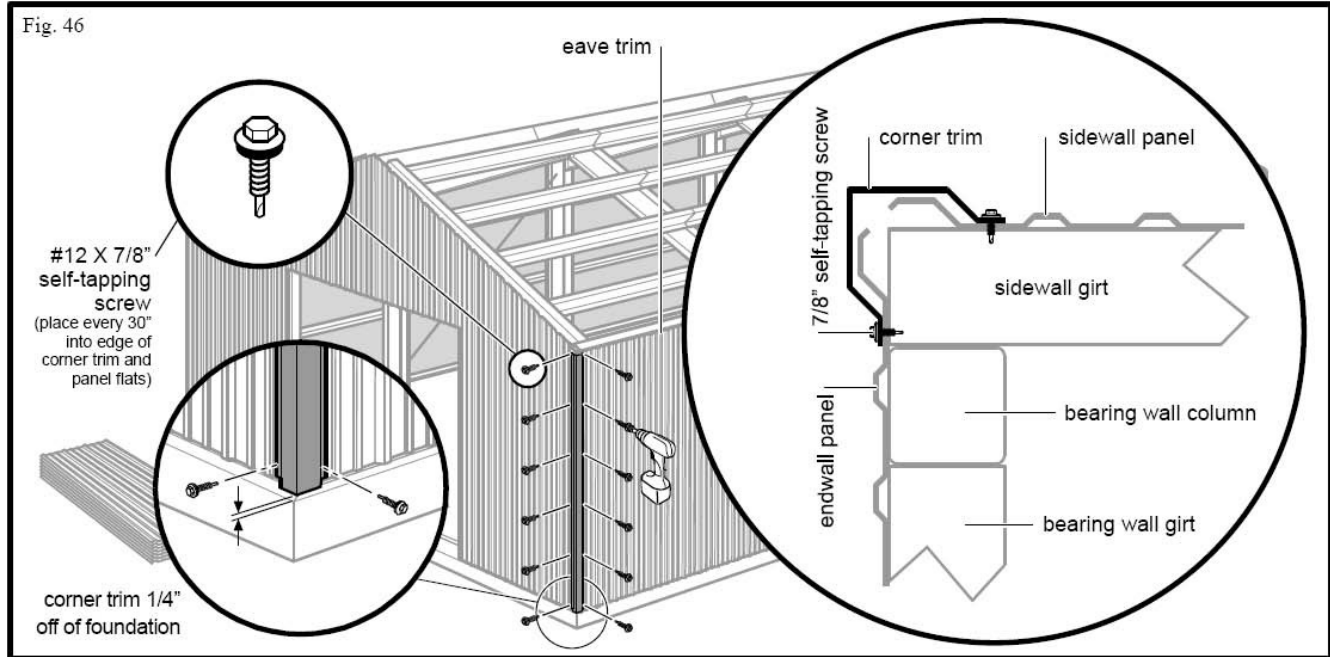

EAVE TRIM/GUTTER COUNTER FLASHING INSTALLATION

23. Prepare to install eave trim (with no gutter) or gutter counter flashing (with gutter).

Notice: If your building does not utilize gutters, perform step 27.1 to install eave trim. If your building requires gutters, perform step 27.2 to install gutter counter flashing.

23.1 Prepare to install the eave trim. (Use this procedure for buildings WITH NO GUTTERS.) (Figure 47)

23.1.1. Seat a joint of eave trim against the sidewall panels then align it to the endwall panel high rib. Using #12 x 7/8" self-tapping screws, attach the eave trim to the sidewall by placing a screw through the trim into the sidewall panel high rib. Place the first screw in the high rib nearest to the endwall and the rest of the screw every 3 feet throughout the length of the trim. The other end of the trim will be secured as the next joint is installed.

23.1.2. Seat the next joint of eave trim against the sidewall panels while backlapping 3" over the preceding joint. Using #12 x 7/8" self-tapping screws, attach the eave trim to the sidewall by placing a screw through the trim into the sidewall panel high rib. Place the first screw in the high rib nearest to the endwall and the rest of the screw every 3 feet throughout the length of the trim. The other end of the trim will be secured as the next joint is installed.

23.1.3. Repeat 27.1.2. until all eave trim is installed. Back lap the last joint 2" to 3" and confirm it aligns with the high rib of the end wall. Trim as necessary.

23.1.4. Repeat step 27.1 on the other sidewall.

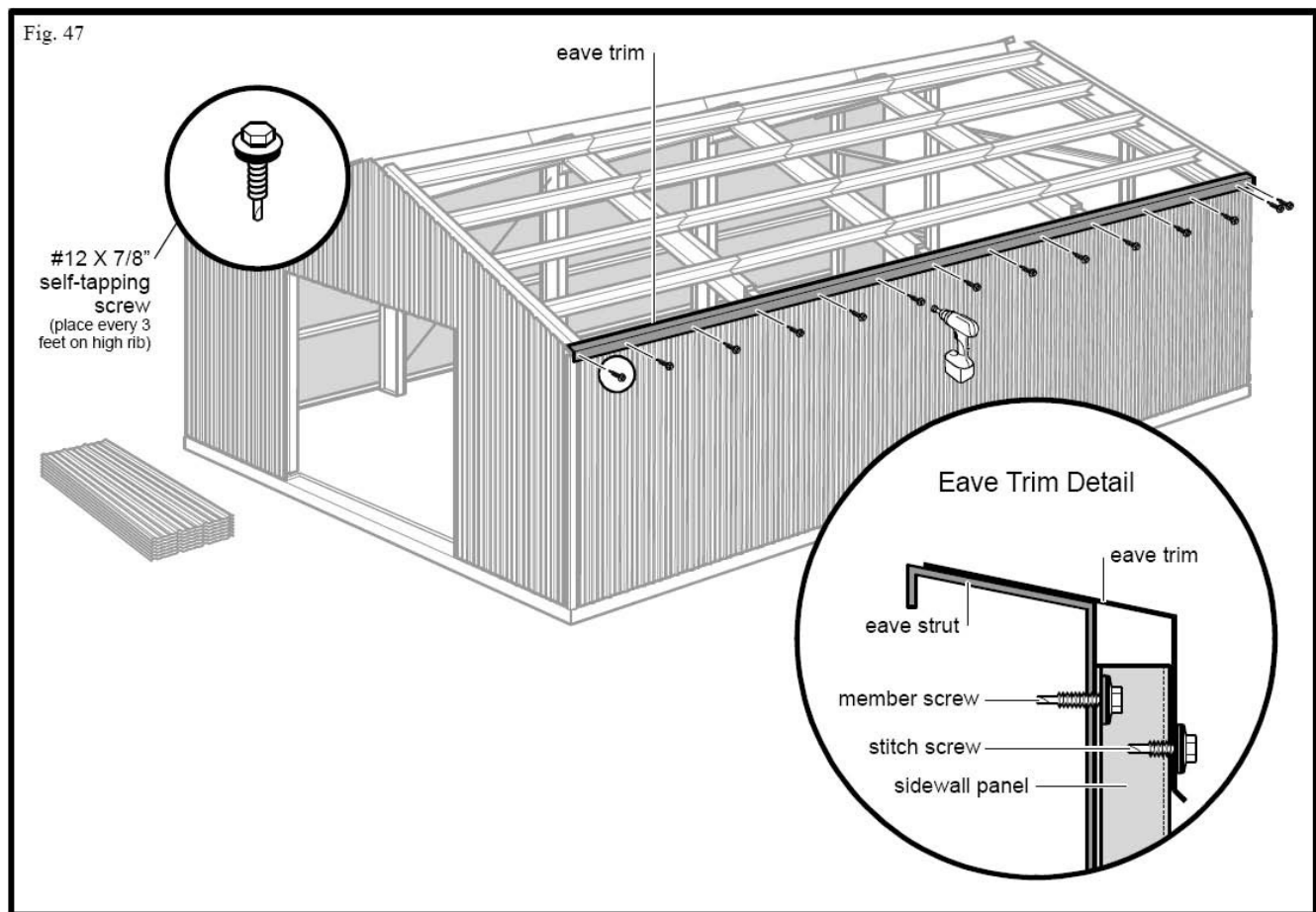

23.2 Prepare to install the gutter counter flashing. (Use this procedure for buildings WITH GUTTERS) (Figure 48)

23.2.1. Seat a joint of counter flashing against the sidewall panels then align it to the endwall panel high rib. Using a #12 x 1-1/4" self-tapping screw, attach the counter flashing to the eave strut by placing a screw through the topside of the flashing into the eave strut. Place the first screw 2" to 3" from the end of the eave strut and the rest of the screws every 3 feet throughout the length of the flashing.

Important: Align the screws so they fall under the roof panel high ribs.

23.2.2. Seat the next joint of counter flashing against the sidewall panels while backlapping 2' to 3" over the preceding joint. Using #12 x 1-1/4" self-tapping screws, attach the counter flashing to the eave strut by placing a screw through the topside of the flashing into the eave strut. Place the first screw 2" to 3" from the end of the eave strut and the rest of the screws every 3 feet throughout the length of the flashing.

23.2.3. Repeat 27.2.2 until all eave trim is installed. Backup the last joint 2" to 3" and confirm it aligns with the high rib of the end wall. Trim as necessary.

23.2.4. Repeat step 27.2 on the other sidewall.

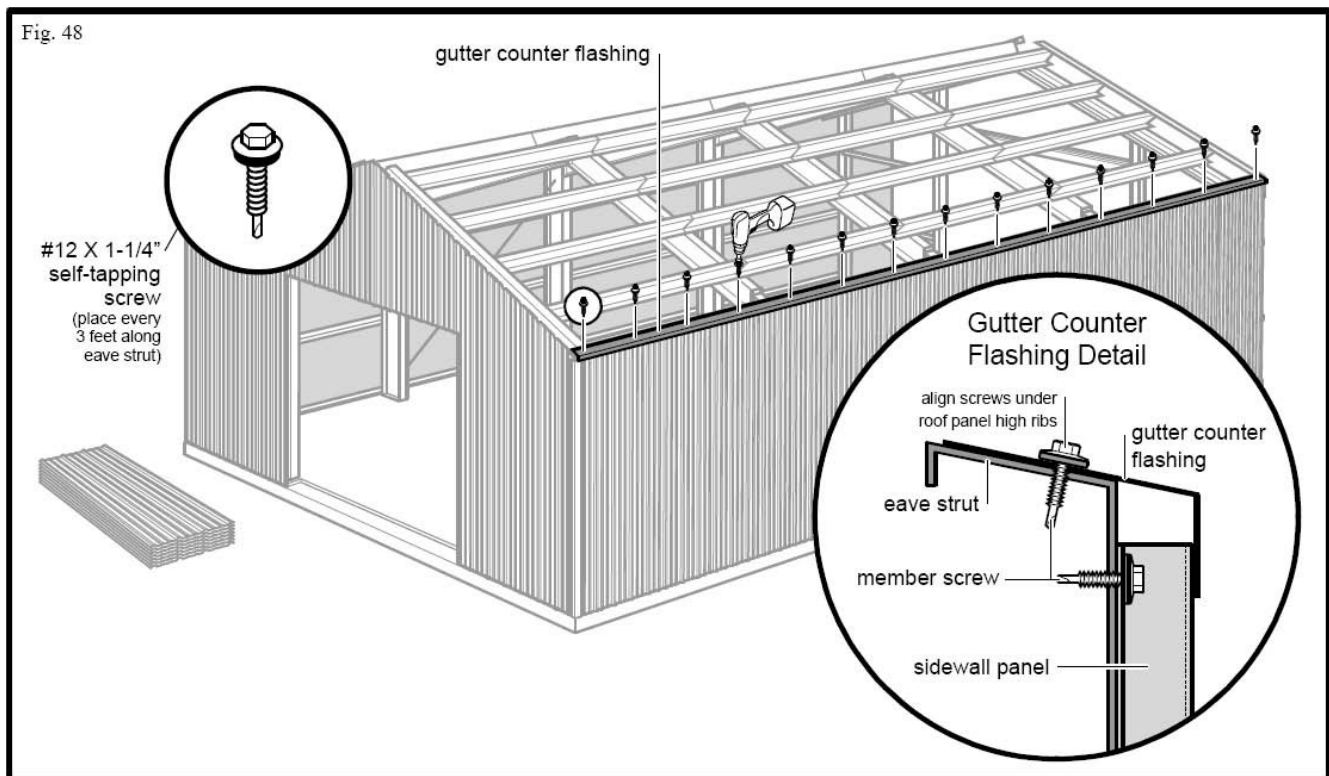

INSTALL ROOF INSULATION, PANELS, AND RIDGE CAP

Pre –Drill Roof Panels

24. Prepare to pre-drill roof panels for easy installation.

24.1 Due to the manufacturing process, oil may have been used to protect panels. Prior to installation, use an approved cleaner to wipe panels free of foreign debris and residue.

Safety Precaution: Wear OSHA approved eye protection when operating drill. Electric tools must be properly grounded. Do not use electrical equipment while standing on wet surfaces.

Warning: Reverse rolled panels require different screw patterns. Refer to the construction drawings for placement.

Lap Screw Detail Tip: Evenly aligned and distributed roof panel screws will yield a professional appearance. Drill the 1/8" lap screw clearance holes down the center of the high lap rib on 20" centers or as specified by the erection drawings (drill the first hole 3" from the bottom edge then distribute as necessary). For cosmetic reasons, place the lap screw clearance holes in the center of the panel's high lap rib.

24.2. To confirm the proper panels are being pre-drilled, measure the panels then compare them to the area (s) to be covered. (Figure 49)

24.2.1. Using a measuring tape measure the panel length, which is the "A to B" dimension.

24.2.2. Using a measuring tape, measure from the peak purlin to outside of the eave trim which is the "C to D" dimension.

Notice: For roofs utilizing a "single sheet run", the "A to B" measurement should be approximately 9" longer than the "C to D" measurement.

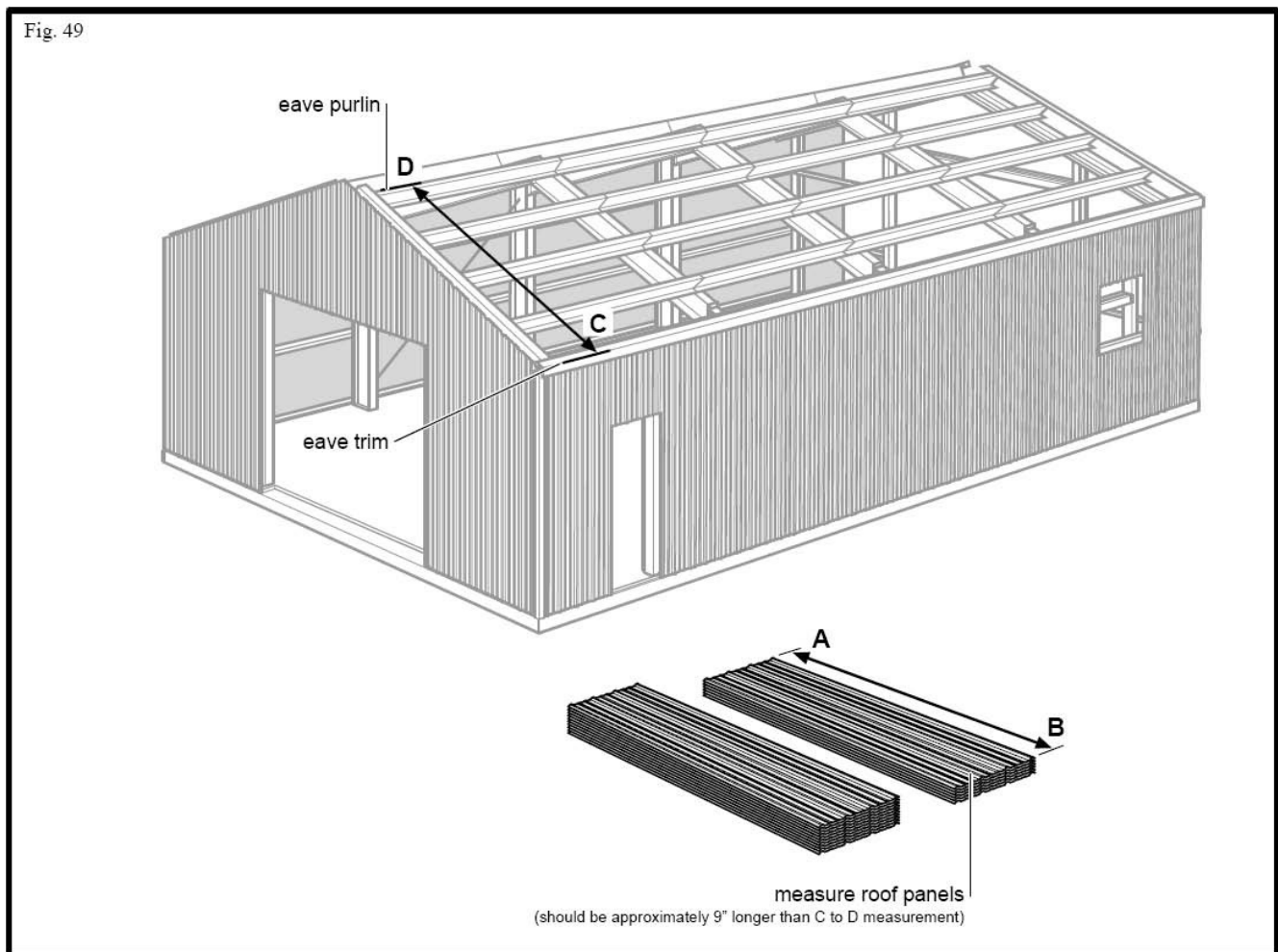

24.3. Prepare to pre-drill the lap screw clearance holes (Figure 50)

Safety Precaution: Pre-drill all roof panels while on the ground.

Important: The lap screw clearance holes are the only holes pre-drilled into the roof panels. Due to possible misalignment, do not pre-drill holes for any eave struts, purlins, or peak purlins.

24.3.1. With the panels (on the ground) pre-arranged in stacks of ten and perfectly aligned, using vice-grip clamps to secure the stack in preparation for drilling. This will help prevent the misalignment.

24.3.2. (Refer to the illustration for lap screw clearance hole placement.) Using a writing utensil and measuring tape, mark the first hole location 2" from the bottom of the panel lap rib then distribute the remaining clearance holes on 20" centers or as specified by the erection drawings .

24.3.3. Using a 1/8" drill bit, carefully drill holes through the panel stacks at the marked locations.

Fig. 50

Pre-drill roof panel "LAP SCREW" clearance holes.

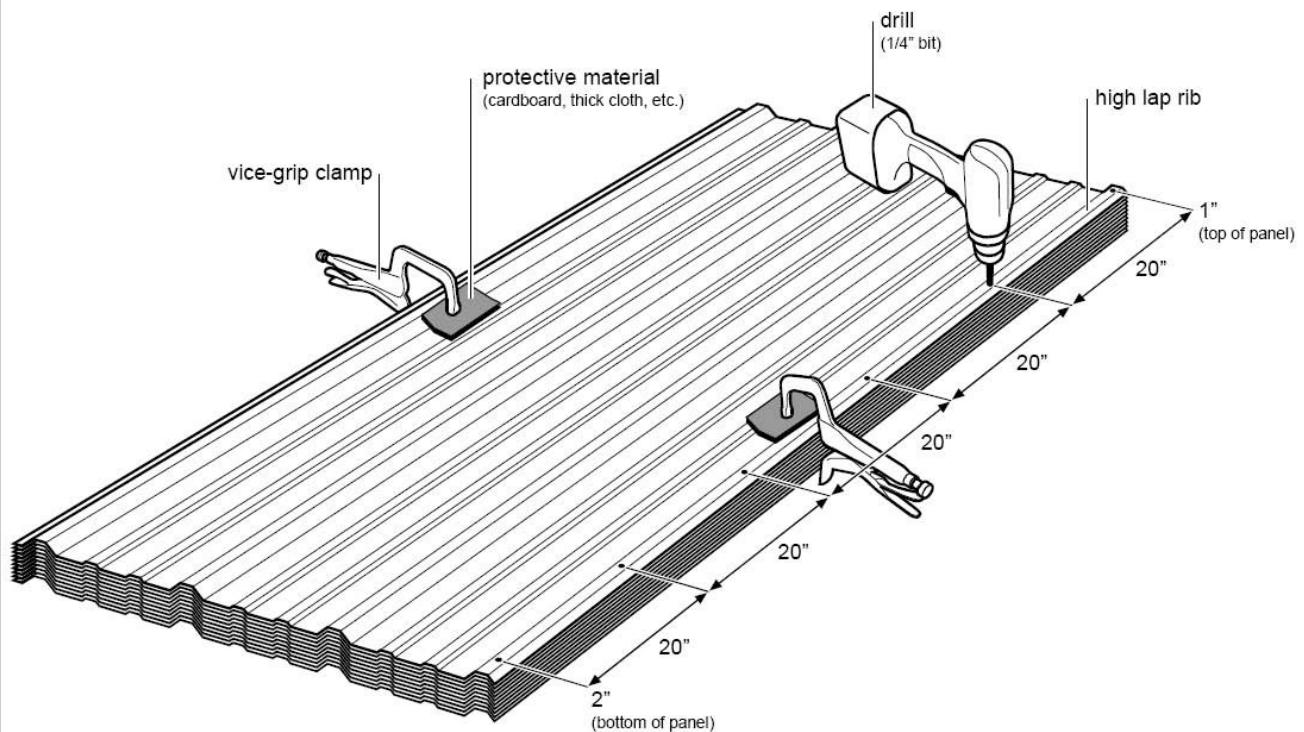

Drilling Roof Panel Lap Rib Clearance Holes

USE 1/4" DRILL BIT FOR CLEARANCE HOLES

1/4" drill bit
(center of high lap rib)



SAFETY PRECAUTIONS FOR ROOF PANEL INSTALLATION

-Prior to beginning each job, safe work practices on all installation duties should be carefully reviewed with installation crews. Lucas Metal Works® strongly recommends that installation crews be continuously trained in safe and productive work practices. To minimize the risk of fall, roof structures, insulation and roof panel installation requires proper training, constant alertness and adequate machinery, tools and safety equipment.

-Never walk on rib edge of panel, near crease in rib at edge of panel or closer than 5 feet of the edge of an unsecured panel.

-Never walk on partially attached on or unattached roof panels! Before the roof is considered a safe and walking surface. It must be secured to the purlins and to the panels on either side. Never consider skylights or translucent panels a safe walking surface. Panels not properly secured may collapse!

-Use only OSHA approved scaffolding, work platforms and walk boards! Never use a single roof panel as a work platform. (Consult OSHA Safety and Health Regulations for the Construction Industry).

-To help prevent injuries from falling objects, hard hats should be worn on job sites.

-Wear rubber sole work boots at all times!

-PANELS MAY BE SLICK! When working on the roof, ALWAYS utilize OSHA approved fall restraints such as safety lines, safety nets, or catch platforms.

25. PREPARE TO INSTALL THE FIRST ROOF PANEL.

Notice: Use this procedure for installing skylights.

Important: Install roof panel rows simultaneously on both sides of the peak.

25.1. Precut the insulation to accommodate the width of the roof. Eave-to-eave according to manufactures instructions listed on roll sheet tag.

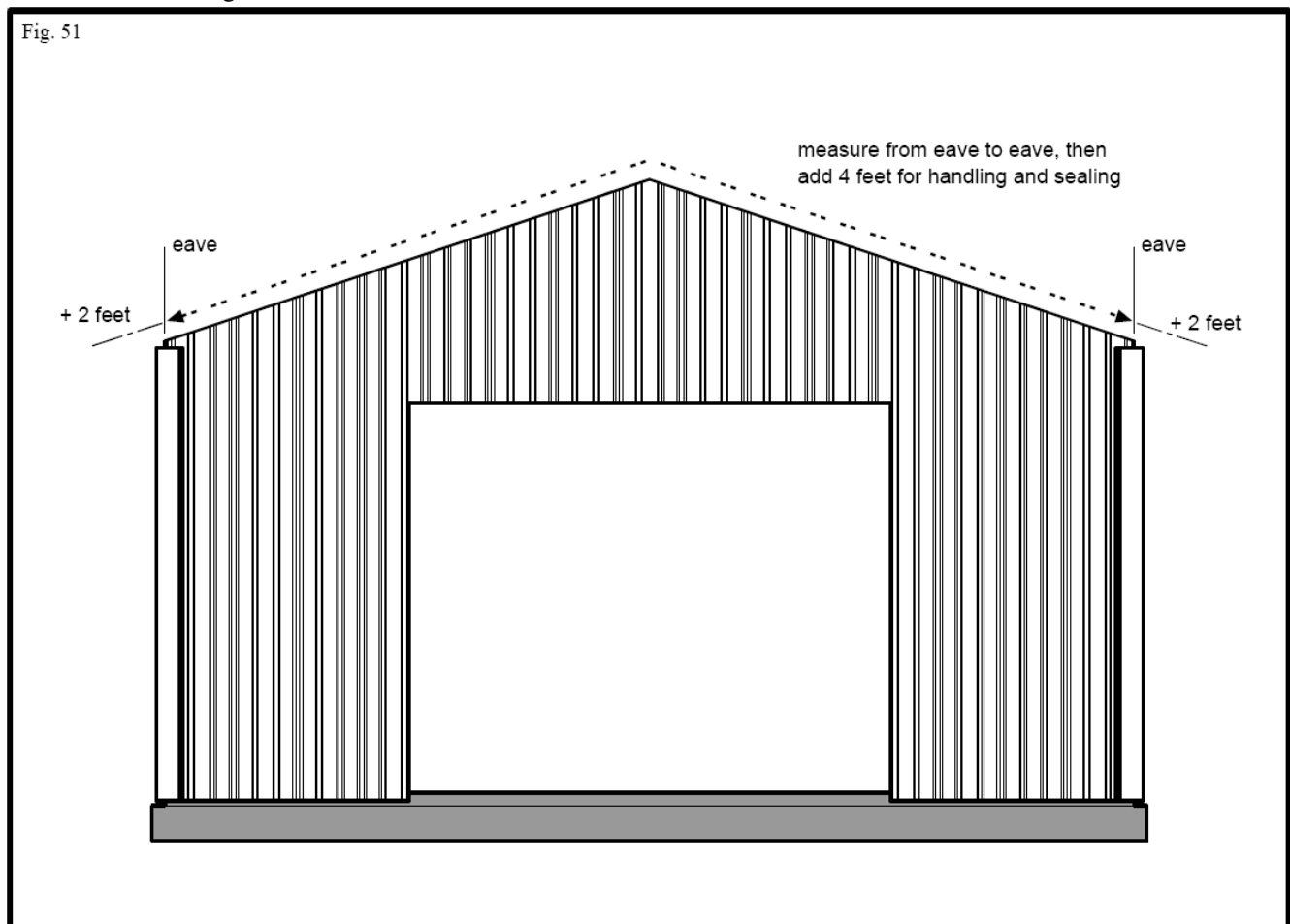

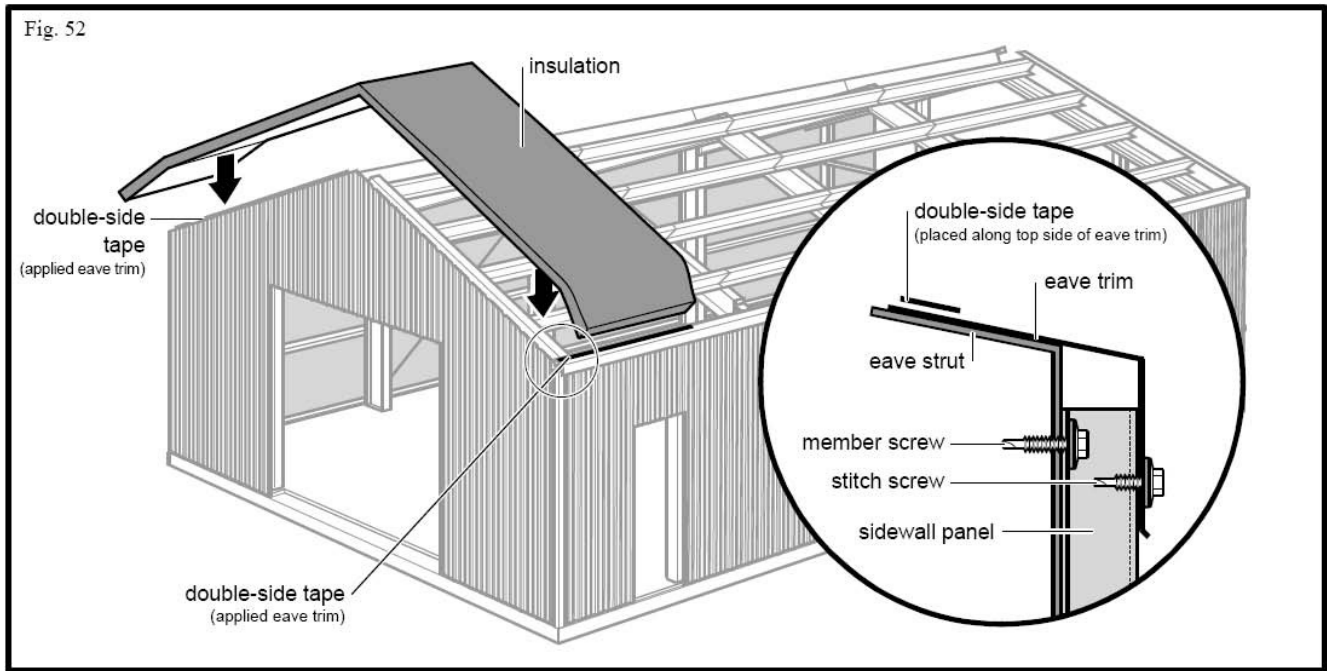
25.2. Install the “starting” row of insulation. (Figure 52)**25.2.1.** Place strips of double-side tape, approximately 7 ft. in length, along the top sides of the eaves’ trim.

SKYLIGHT PANEL CLUSTER INSTALLATION GRID (figure 54)

Fig. 54

Single Roof Panel Installation Patterns

Single Panel Run Roofing

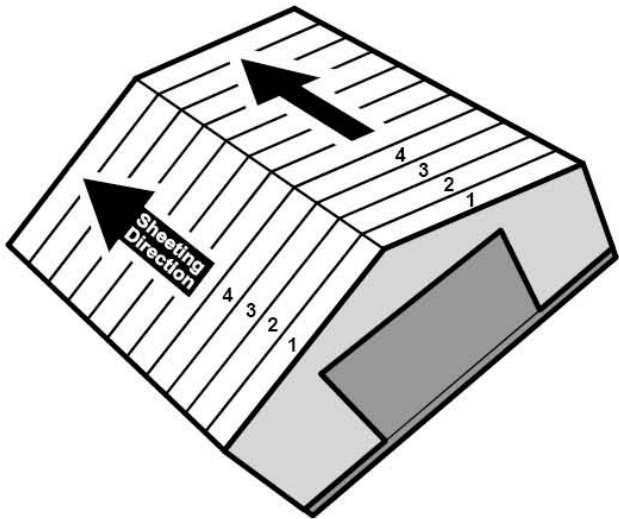

Single Panel Run Roofing with Sky Lights

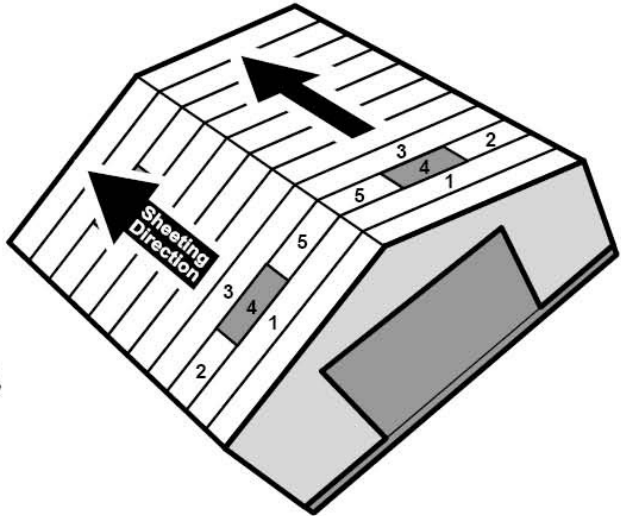

Multiple Roof Panel Installation Patterns

Multiple Panel Run Roofing

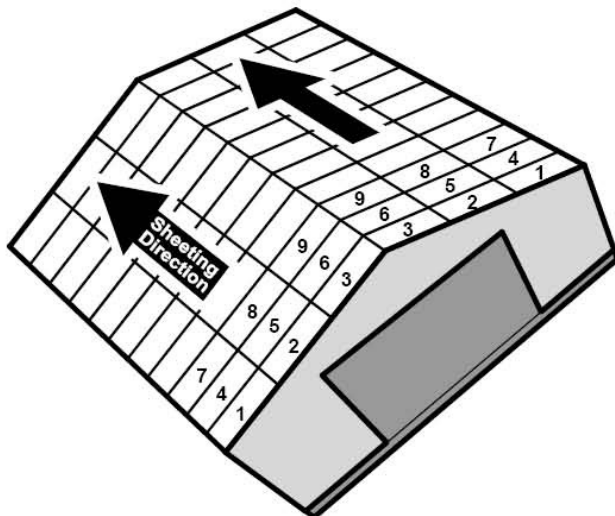

Multiple Panel Run Roofing with Sky Lights

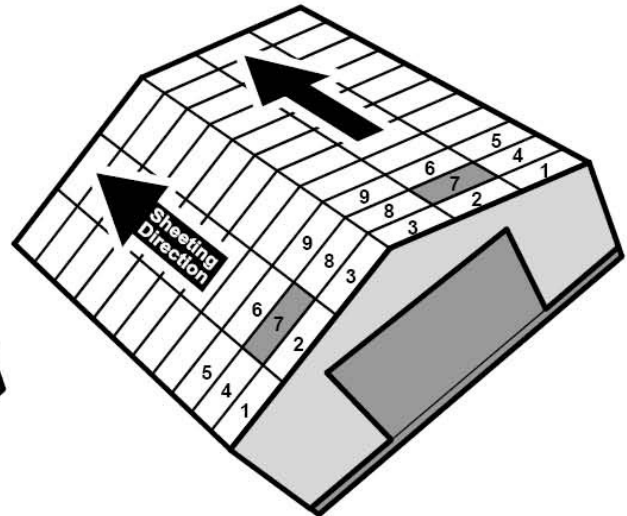

25.3. Due to the manufacturing process, oil may have been applied to help protect panels from corrosion. Prior to installation, use a clean rag and an approved cleaner to wipe panels free of foreign debris and residue.

Safety Precaution: Do not walk on unsecured panels. Continuously warn crews to never step on unsecured roof panels.

Safety Precaution: In case of multiple roof panel runs, do not install vice grip clamps or fasteners on purlins where panels overlap. Completely secure one panel at a time before clamping the next panel into place.

Important: Check the Construction Drawings to determine the roof overhang at the eave.

25.4. Set the “starting” roof panel in place and align the center of first high rib with framing line.

25.4.1. Using vice-grip clamps, secure both ends of the roof panel to the peak purlin and eave strut.

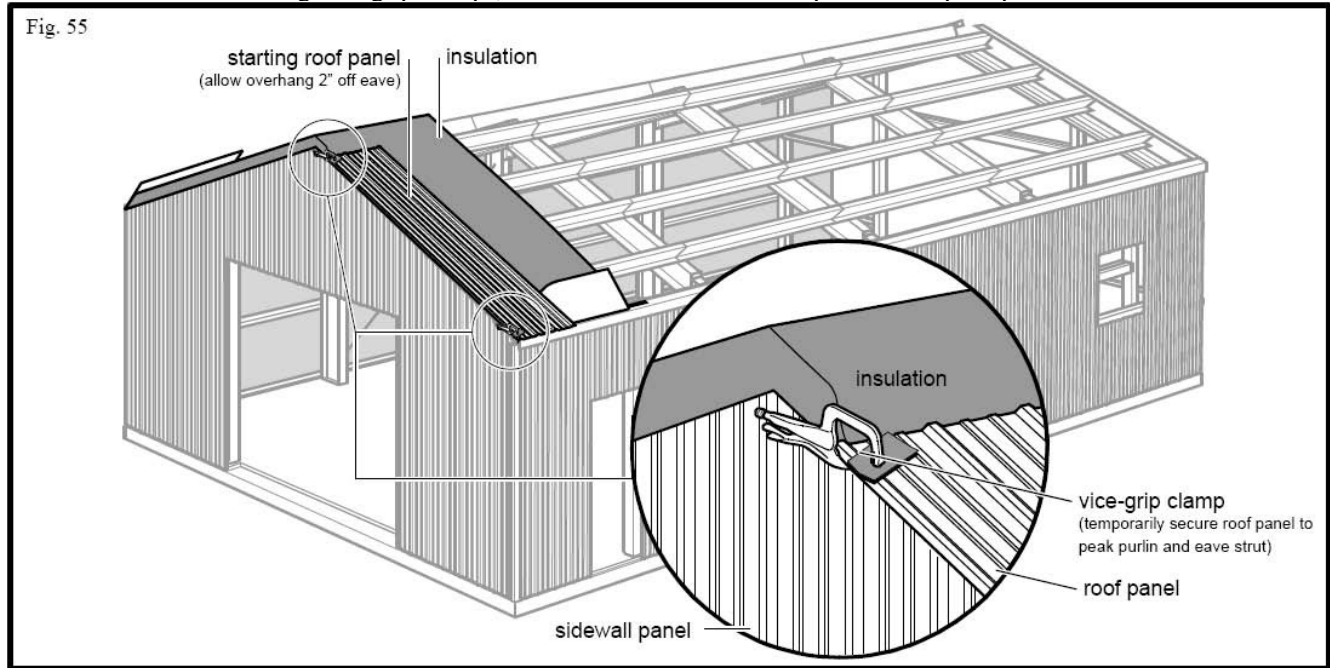

25.6. Place the “starting” inside closure strip on top of the eave trim (as specified by manufacturer) and cut off as necessary, just outside of the insulation’s edge. (Figure 56)

25.6.1. Splice a “full” inside closure to the “starting” inside closure and apply along the top of the eave (as specified by the manufacturer).

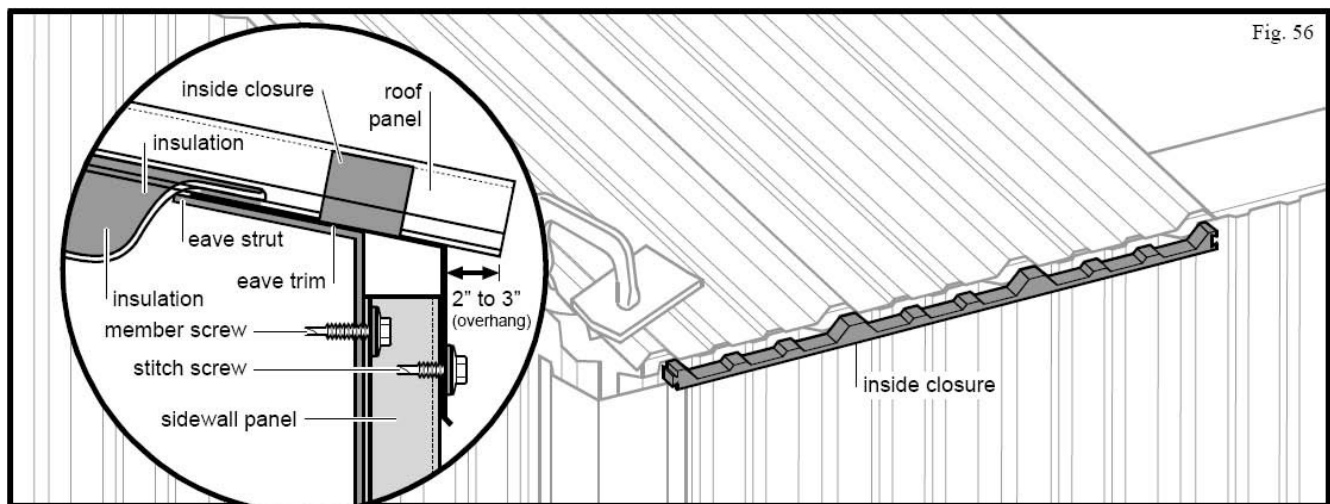

25.7. Prepare to secure the “starting” roof panel (s) to the eave strut, purlins, and peak purlin. (Figure 57)

25.7.1. Using a chalk line, align the screw holes to the corner of the eave trim. On the upside of the inside closure, on approximately 6” centers, use #12 x 1-1/4” self-tapping screws to secure the roof panel to the eave trim.

25.7.2. Using a chalk line, align the screw holes to the center of the purling. Use #12 x 1-1/4” self-tapping screws to secure the roof panel to the purlins, on approximately 12” centers. Do not allow screws to be covered by an overlapping panel.

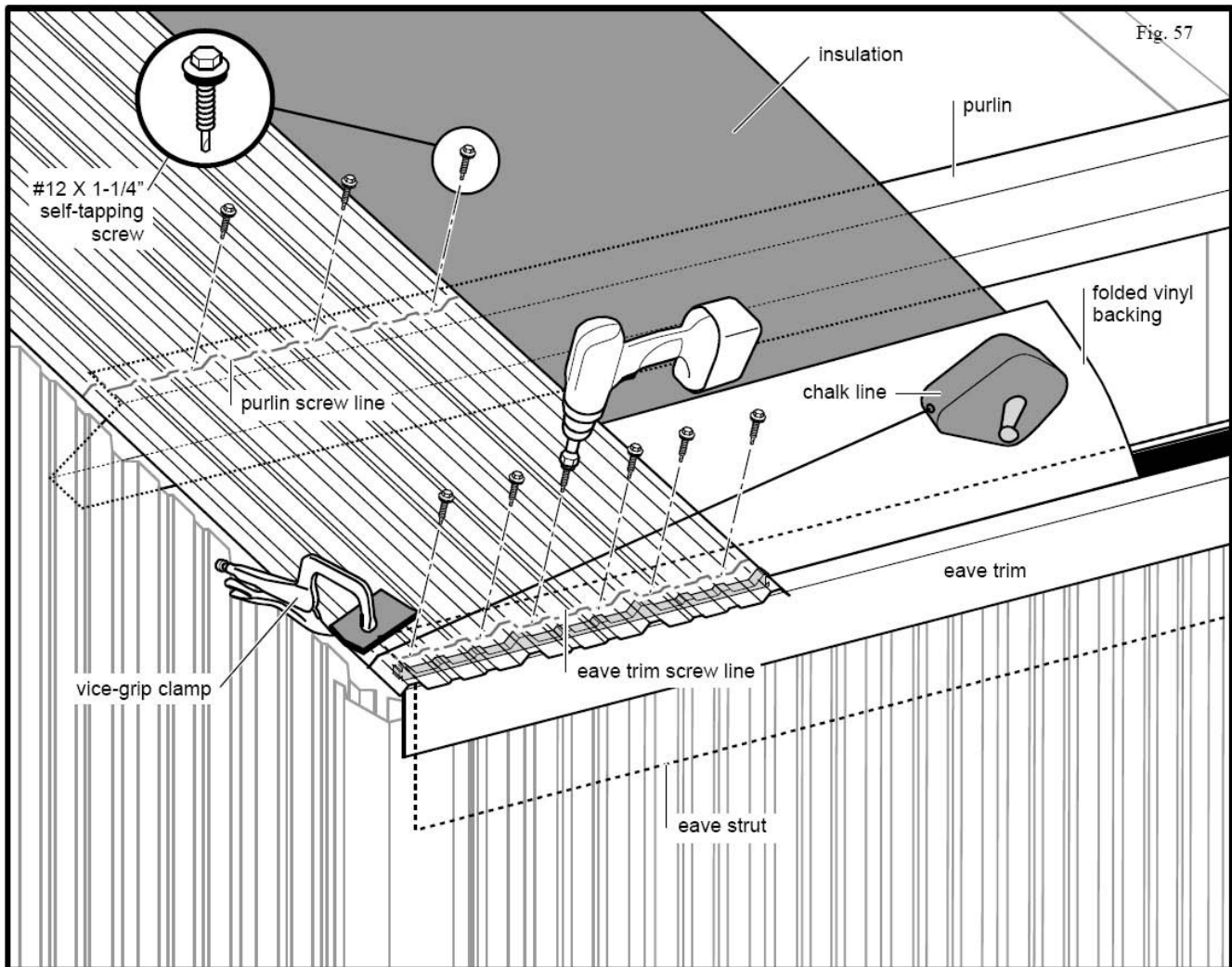

25.7.3. If your building has multi-run roof panels, perform the following steps (Figure 58);

1. To prevent water from seeping between the panels, use sealant tape, as shown. With the release paper in place, press firmly along the length of the sealant to insure proper adhesion. The sealant must be continuous, no voids can be present.
2. Remove the release paper then set the overlapping panel in place at this time.
3. Overlap the panel a minimum of 3" or as specified by the Construction Plans.
4. To secure the "lap ends" to the purlins, use #12 x 1-1/4" self-tapping screws on approximately 6" centers. *The screws must be installed above the sealant tape line.*

Safety Precaution: FALL HAZARD! DO NOT WALK BETWEEN THE PEAK PURLIN AND NEIGHBORING PURLIN UNTIL THE TOP OF THE PANEL HAS BEEN SECURED. For walking purposes, temporarily secure the top of the panel to the peak purlin by placing (2) screws, in the "flats", approximately 10" from both edges of the panel. These two temporary screws must be removed just prior to installing the ridge cap.

25.7.4. Temporarily secure the top of the roof panel to the peak purlin by placing (2) screws, in the "flats", approximately 10" from both edges of the panel. These screws must be removed prior to ridge cap installation.

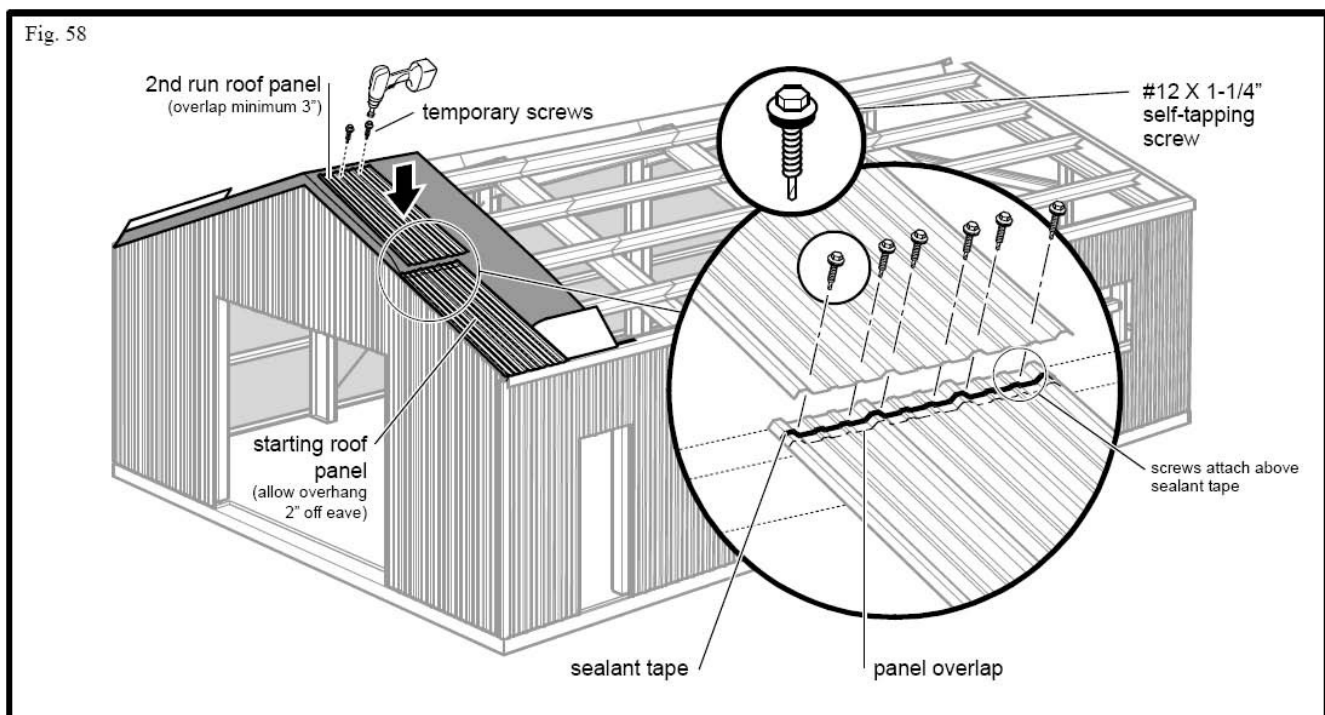

26. Prepare to install the remaining roof panels.

SKYLIGHT PANEL CLUSTER NOTICE: See Install SKYLIGHT PANEL CLUSTER on page 73. Use this procedure for installing skylights. Skylight panel must lap over panels to the left, right, and below.

Important: The insulation must be compressed between purlins, eave struts and roof panel. Very thick or dense insulation will not compress adequately resulting in waviness in certain types of roof panels.

26.2. Install a row of insulation. (Figure 59)

26.2.1. Place strips of double-side tape, approximately 7 ft. in length, along the top sides of the eaves' trim.

26.2.2. Place the insulation on the roof, running from eave-to-eave. Stretch the insulation until tight and smooth.

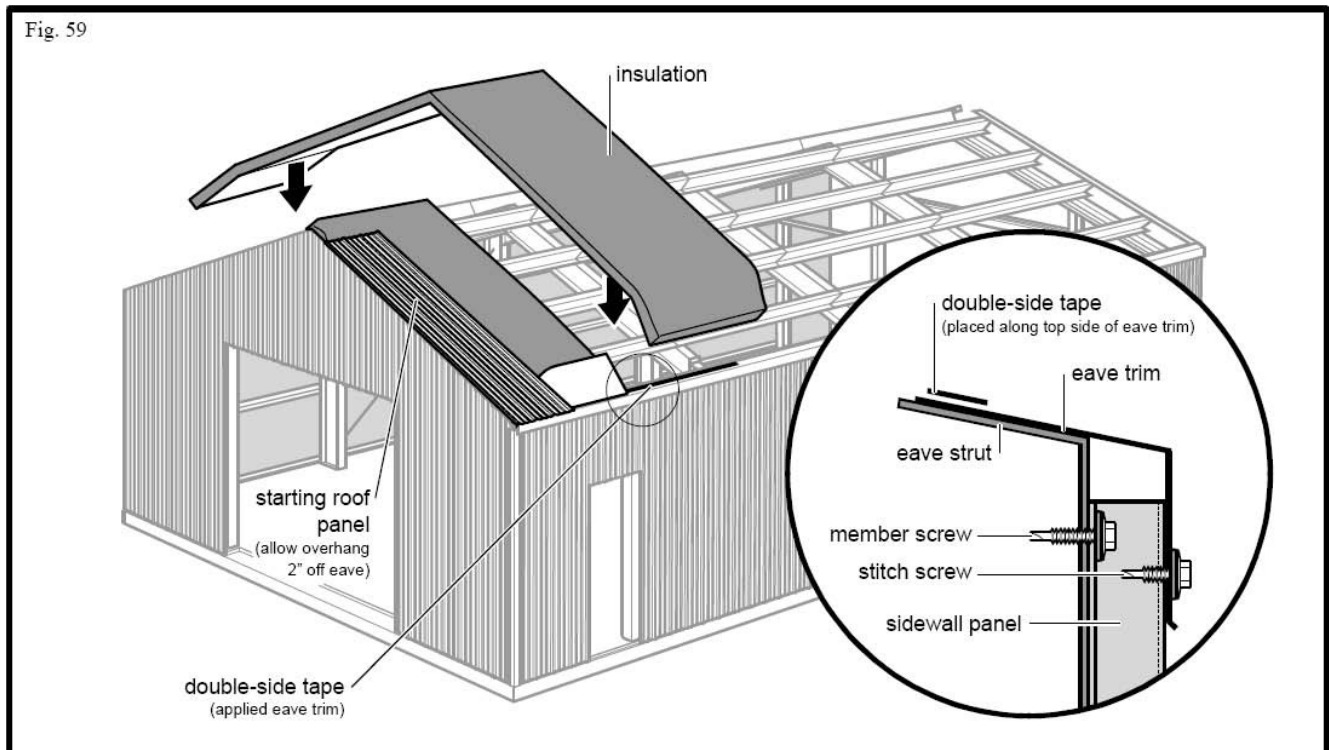

26.3. Trim the insulation for roof panel installation. (Figure 60)

26.3.1. Using a utility knife, without cutting through the vinyl backing, trim the “insulation” even with the eave trim.

26.3.2. Trim the vinyl backing off about 1 foot past the insulation, leaving a flap to fold back protecting the insulation’s edge from weather.

Important: Install the roof panels in conjunction with the insulation. Do not install more insulation on the roof than can be covered by roof panels before the work period ends. Do not allow the insulation to get wet.

Safety Precaution: Insulation has no load bearing strength. Do not walk on insulation. Observe all proper safety procedures when handling fiberglass insulation, such as dust masks, gloves, and long sleeved shirts, to minimize contact with the insulation fibers.

Important: The insulation side laps must be sealed to minimize temperature loss and help prevent condensation.

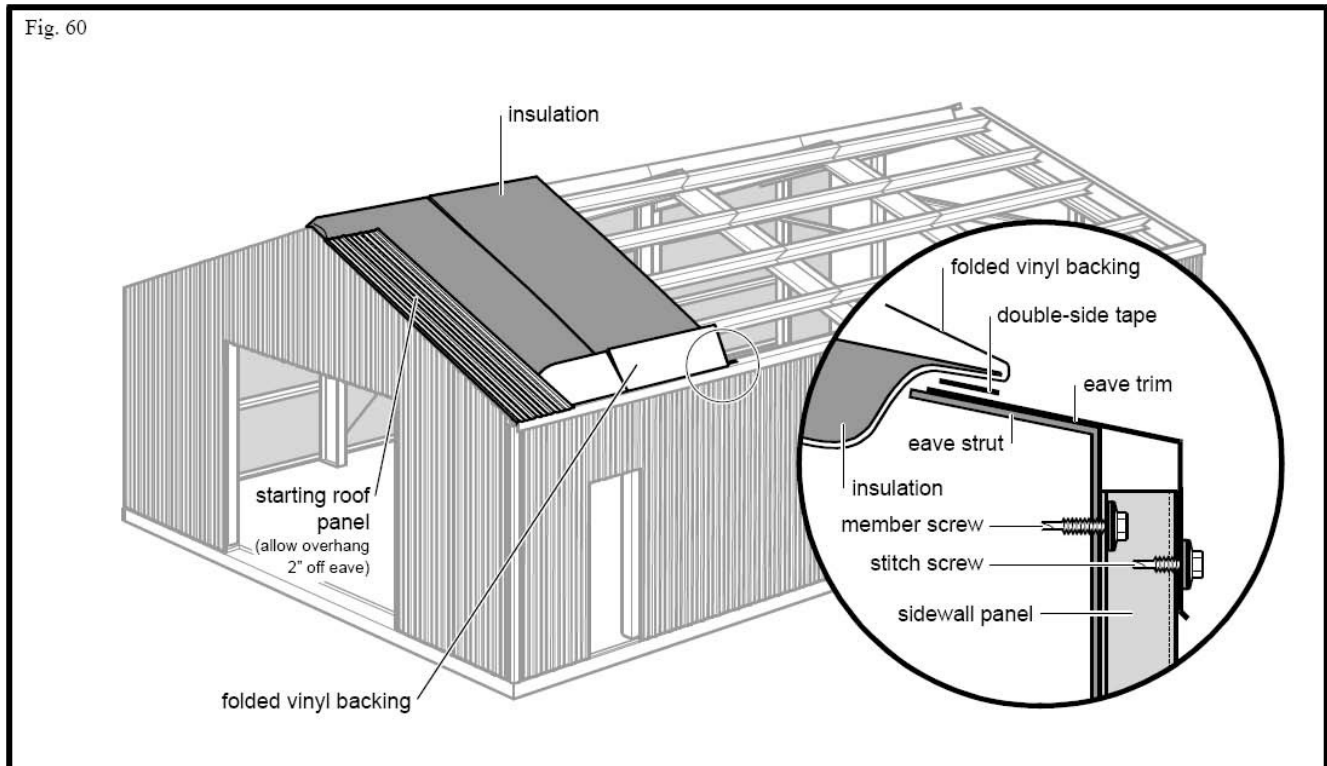

26.4. Prepare to apply sealant tape to the installed roof panel sidelap for the next panel installation. (Figure 61)

Important: So that water cannot seep into the lap, the sealant tape should always be positioned to the outer edge of the panel rib. Voids will be created in the seal if stitch screws penetrate the sealant.

26.4.1. Prior to installing sealants, use a clean rag and approved cleaner to wipe the mating sidelap surfaces free of foreign debris and residue.

26.4.2. Apply the sidelap sealant tape to the weather side edge of the lower panel's high lap rib (as shown)

26.4.3. Be careful not to pull the sealant tape away from the panel while removing the protective paper from the sealant tape.

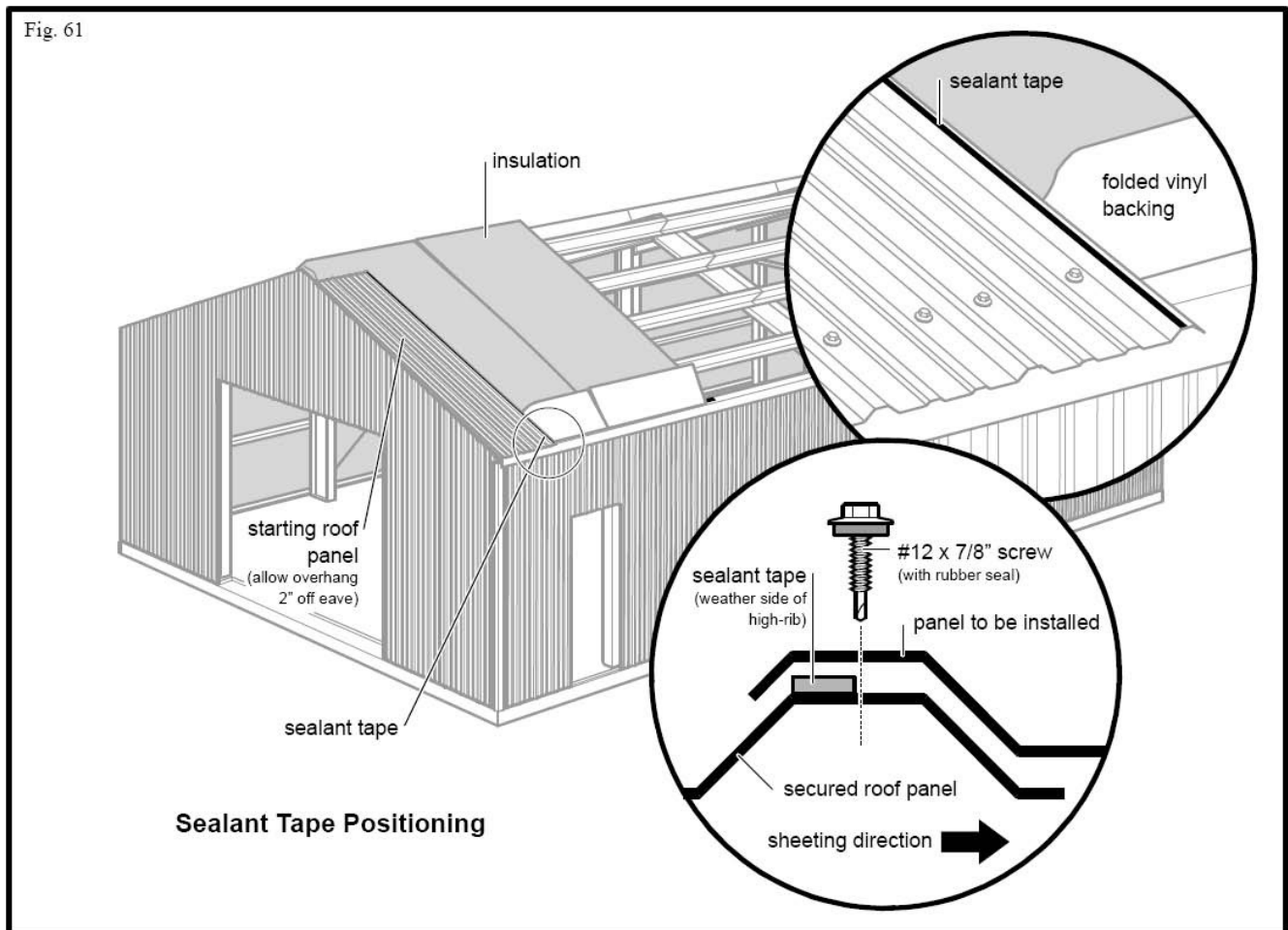

Safety Precautions: Continuously warn crews to never step on unsecured roof panels.

Safety Precaution: In case of multiple roof panel runs, do not install vice-grip clamps or fasteners on purlins where panels overlap. Completely secure one panel at a time before clamping the next panel into place.

Important: Check the Construction Drawings to determine the roof overhang at the eave.

26.5. Prepare to install the next roof panel. (Figure 62)

26.5.1. Due to the manufacturing process, oil may have been applied to help protect panels from corrosion. Prior to installation, use a clean rag and an approved cleaner to wipe panels free of foreign debris and residue.

26.5.2. Align and lay the panel in place, sealing it appropriately to the sealant tape.

26.5.3. Using vice-grip clamps or appropriate fasteners, secure both ends of the roof panel to the peak purlin and eave strut.

26.5.4. Using #12 x 7/8" self-tapping screws with sealing washers, stitch the lapping ribs together on approximately 20" centers (set by the pre-drilled clearance holes).

26.5.5. Splice an inside closure to the preceding inside closure and apply along the top of the eave trim (as specified by manufacturer), just outside of the insulation's edge.

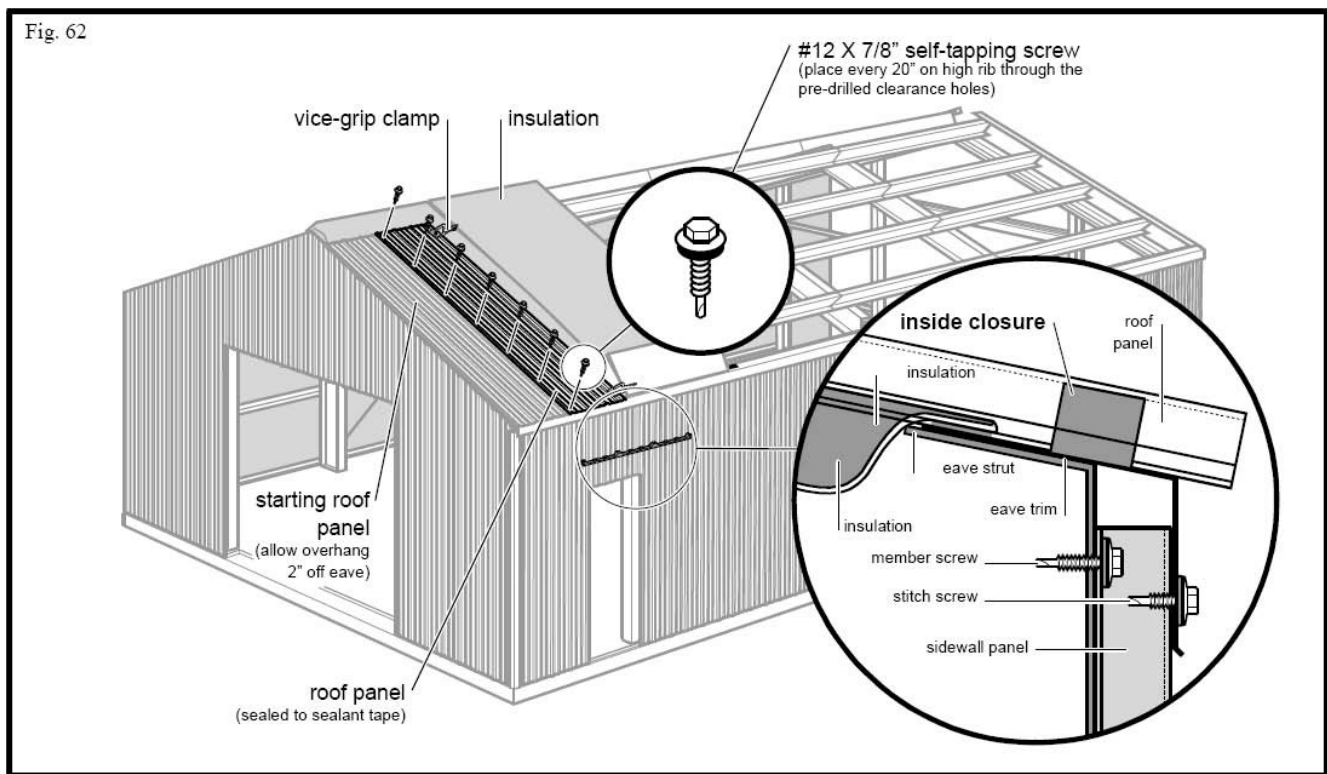

26.6. Secure the roof panel to the eave strut, purlins, and peak purlin.(Figure 63)

26.6.1. Using a chalk line, align the screw holes to the center of the eave trim. On the upside of the inside closure, on approximately 6” centers, use #12 x 1-1/4” self-tapping screws to secure the roof panel to the eave trim.

26.6.2. Using a chalk line, align the screw holes to the center of the purlin. Use #12 x 1-1/4” self-tapping screws to secure the roof panel to the purlins, on approximately 12” centers. Do not allow screws to be covered by an overlapping panel.

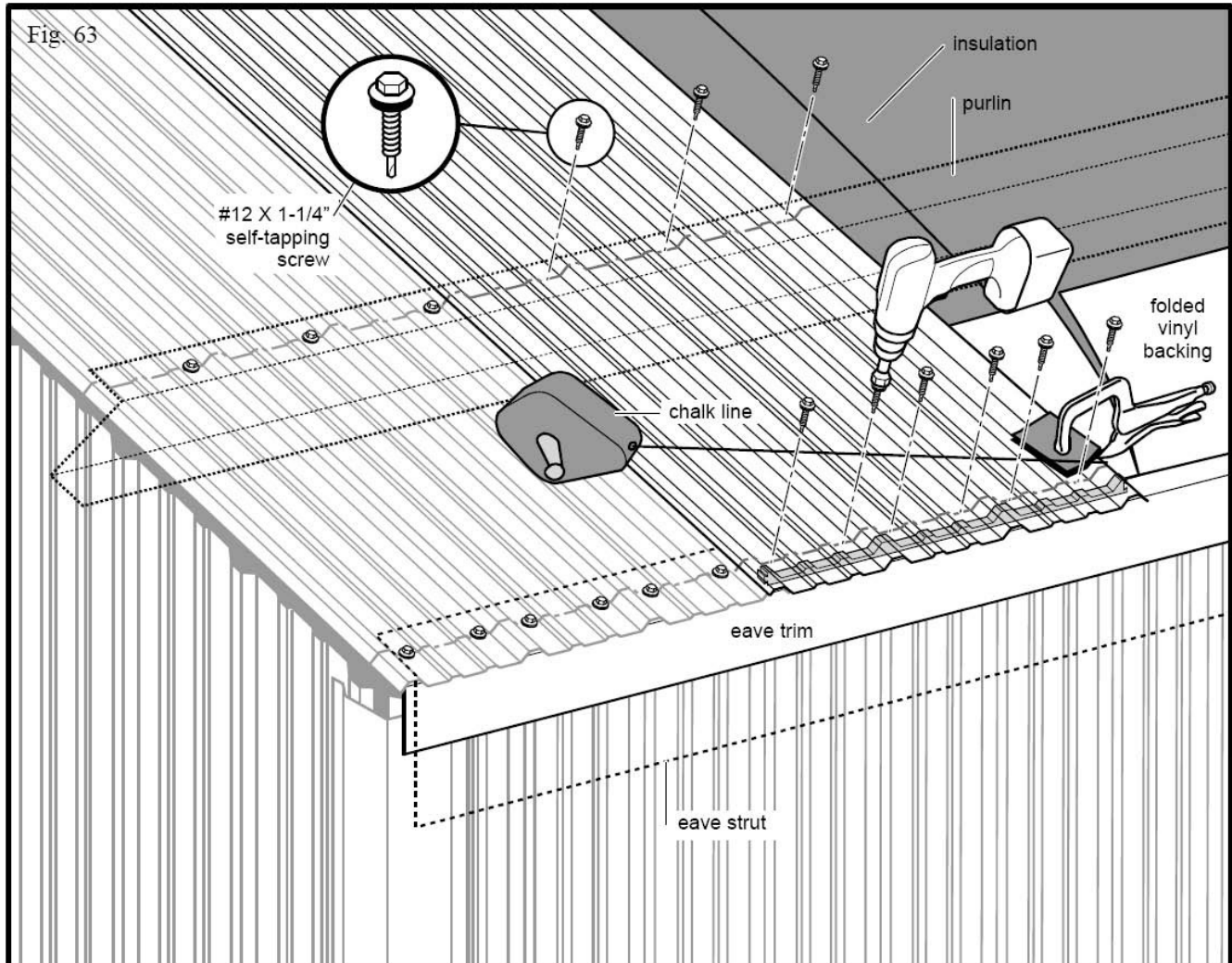

If your building has overlapping panels, perform the following steps (Figure 64):

1. Ensure the top row of roof panels overlap the bottom row of roof panels.
2. To prevent water from seeping between the panels, use sealant tape, as shown. With the release paper in place, press firmly along the length of the sealant to insure proper adhesion. The sealant must be continuous, no voids can be present.
3. Remove the release paper then set the overlapping panel in place at this time.
4. Overlap the panel a minimum of 3" or as specified by the Construction Plans.
5. To secure the "lap ends" to the purlins, use #12 x 1-1/4" self-tapping screws on approximately 6" centers. The screws must be installed above the sealant tape line.

Safety Precaution: FALL HAZARD! DO NOT WALK BETWEEN THE PEAK PURLIN AND NEIGHBORING PURLIN UNTIL THE TOP OF THE PANEL HAS BEEN SECURED. For walking purposes, temporarily secure the top of the panel to the peak purlin by placing (2) screws, in the "flats", approximately 10" from both edges of the panel. These two temporary screws must be removed just prior to installing the ridge cap.

- 26.6.3.** Temporarily secure the top of the roof panel to the peak purlin by placing (2) screws, in the "flats", approximately 10" from both edges of the panel. These two temporary screws must be removed just prior to installing the ridge cap.

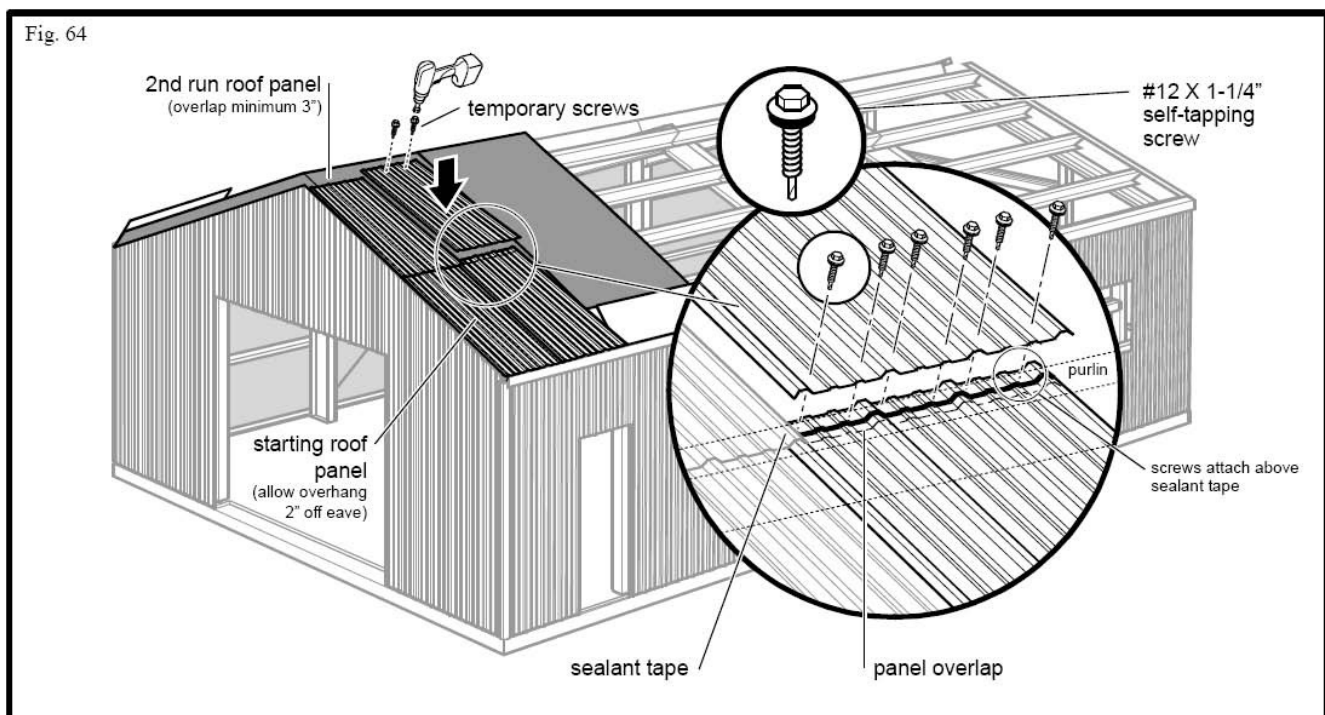

Important: Sweep up all drill shavings from panels to avoid surface rust and damage to panel finish.

- 26.7** Repeat step 30 until the roof is complete.

Important: Backlapping is routinely done to the last roof panel to match panel coverage to building length. This installation method can trap moisture, creating an environment which is conducive to rust and metal failure. Field cut the panel to the width necessary to finish covering the roof. Always install the cut edge of the panel toward the outside edge of the roof, not toward the lap edge.

- 26.8** Field cut the panel to the width necessary to finish covering the roof. Always install the cut edge of the panel toward the outside edge of the roof, not toward the lap edge.

RIDGE CAP INSTALLATION

27. Prepare to install the “starting” ridge cap.

27.1.2 To get the ridge caps properly aligned, set a ridge cap at each end of the roof and secure as necessary (Figure 65)

27.1.3 To prevent water from seeping under the ridge cap, use sealant tape, as shown. With the release paper in place, press firmly along the length of the sealant to insure proper adhesion. The sealant must be continuous, no voids can be present.

27.1.4 Ensure both edges of the ridge caps extend over the peak purlins. Overlap the panel a minimum of 3” or as specified by the Construction Plans. Remove the release paper then set the overlapping panel in place at this time.

27.1.5 To secure the “lap ends” to the purlins, use #12 x 1 ¼” self-tapping screws on approximately 6” centers. **The screws must be installed above the sealant tape line.**

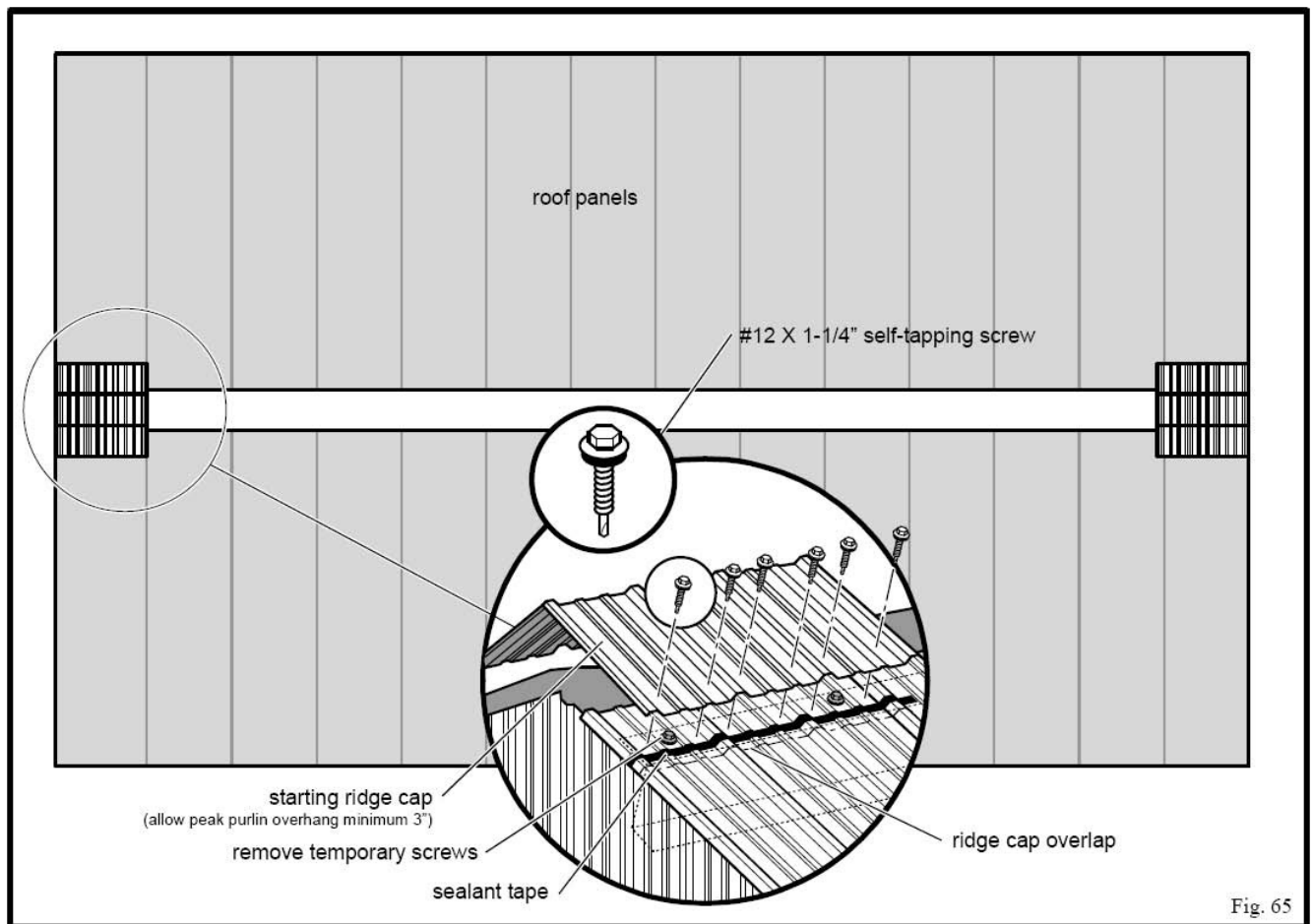

27.2 Using a chalk line, pop a line as necessary to ensure proper ridge cap alignment. (Figure 66)

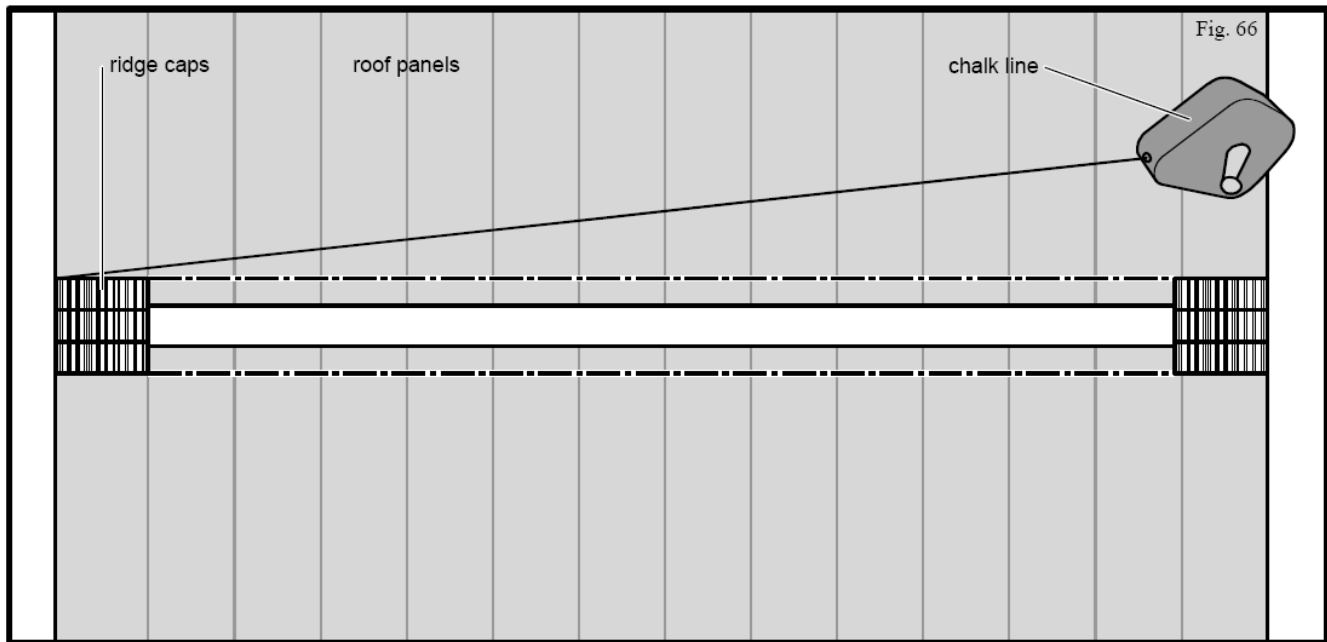

27.3 To prevent water from seeping between the panels and ridge caps, securely place sealant tape along both sides of the roof, just below the screw line and along outer edge of the lap rib. With the release paper in place, press firmly along the length of the sealant to insure proper adhesion. The sealant must be continuous, no voids can be present. (Figure 67)

27.2 Prior to setting the ridge cap into place, remove the (2) temporary screws securing the panels to the peak purlin.
Safety Precaution: FALL HAZZARD! DO NOT WALK BETWEEN THE PEAK PURLIN AND NEIGHBORING PURLIN UNTIL THE TOP OF THE PANEL HAS BEEN SECURED.

27.3 Peel and tear away the release paper as the ridge cap is installed. Carefully align the ridge cap to the chalk line.
 Important: Voids will be created in the seal if stitch screws penetrate the sealant.

27.4 Use #12 x 1 1/4" self-tapping screws, in the "flats", to secure the ridge cap to the peak purlins on approximately 6" centers. Do not allow screws to be covered by an over-lapping ridge cap. The screws must be installed above the sealant tape line.

27.5 Repeat steps 31.3. through 31.6. until all ridge caps are installed. Seal and overlap the last ridge cap as necessary.
Important: Sweep up all drill shavings from panels to avoid surface rust and damage to panel finish.

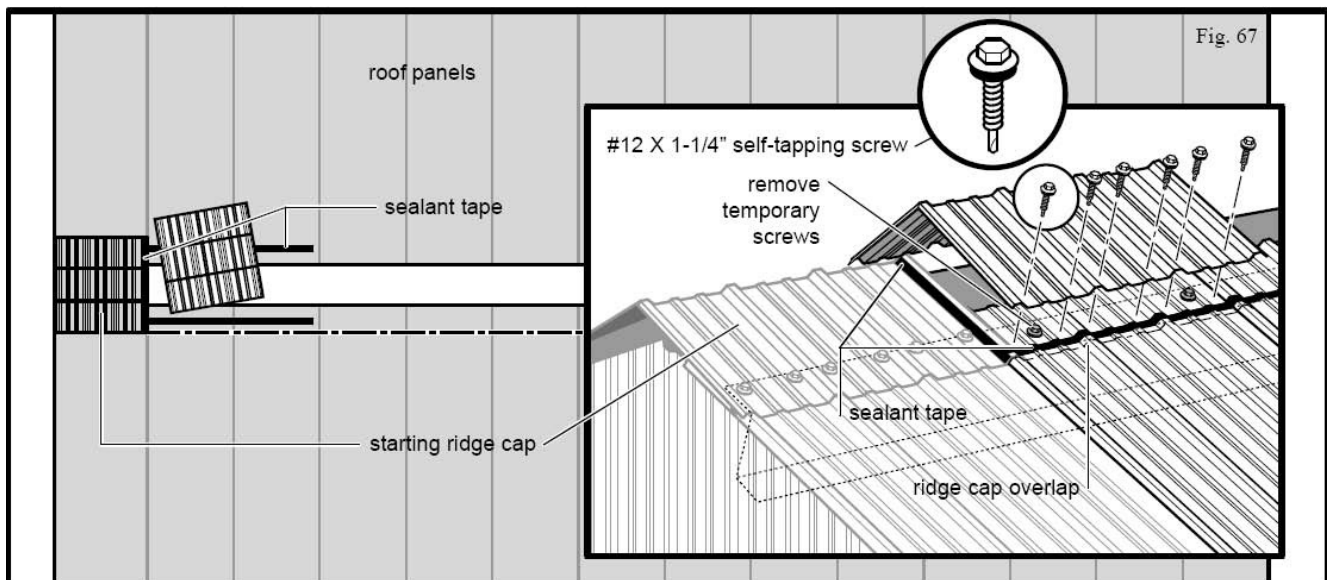

INSTALL GUTTERS, DOWNSPOUTS, RAKE TRIM, AND PEAK BOXES

Gutter and Downspout Installation

28. Prepare to install the gutters and downspouts. (optional)

Notice: If your building does not have gutters and downspouts, please advance to step 34.

28.1. Prepare the gutters for installation (Figure 68)

28.1.1. Place an end cap 1" inside a "starting" joint of gutter.

28.1.2. Using pop rivets, secure the end cap inside the gutter joint.

28.1.3. Using an approved caulk, seal the end cap as necessary.

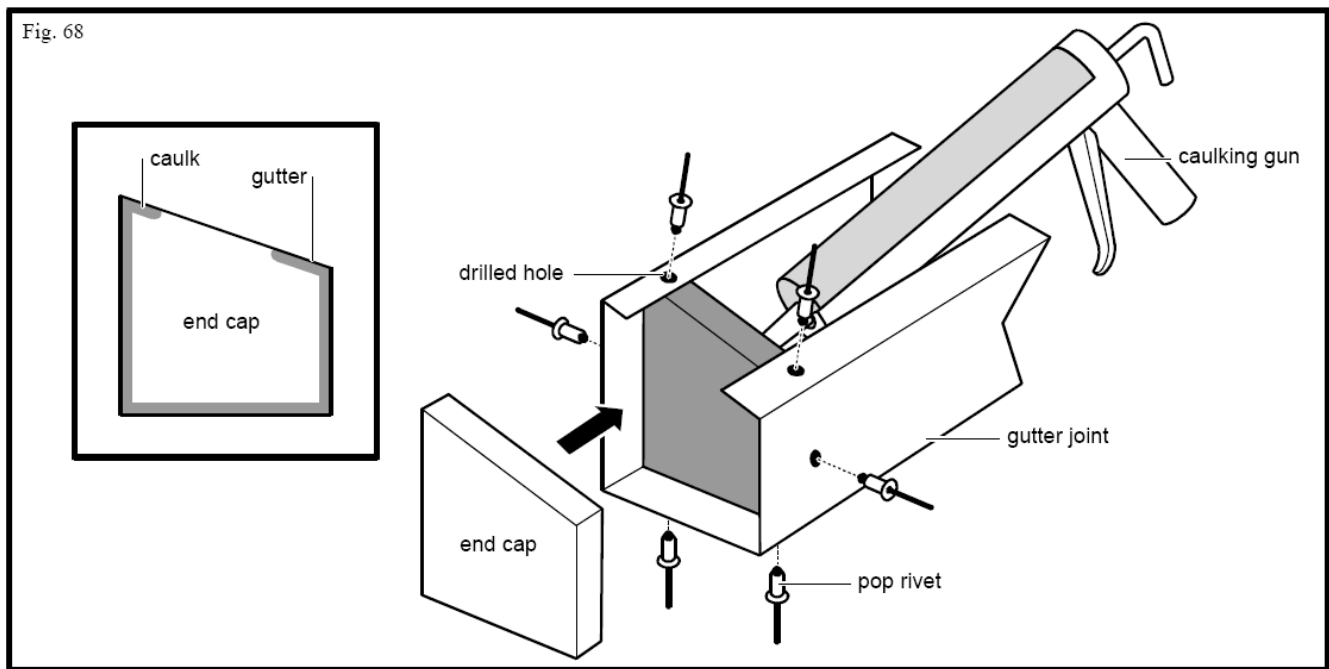

Notice: Typically, downspouts are placed near the frame lines.

28.1.4. To ensure proper gutter installation, carefully measure and mark the bottom side of the gutter joint. Place downspouts in the desired locations. (Figure 69)

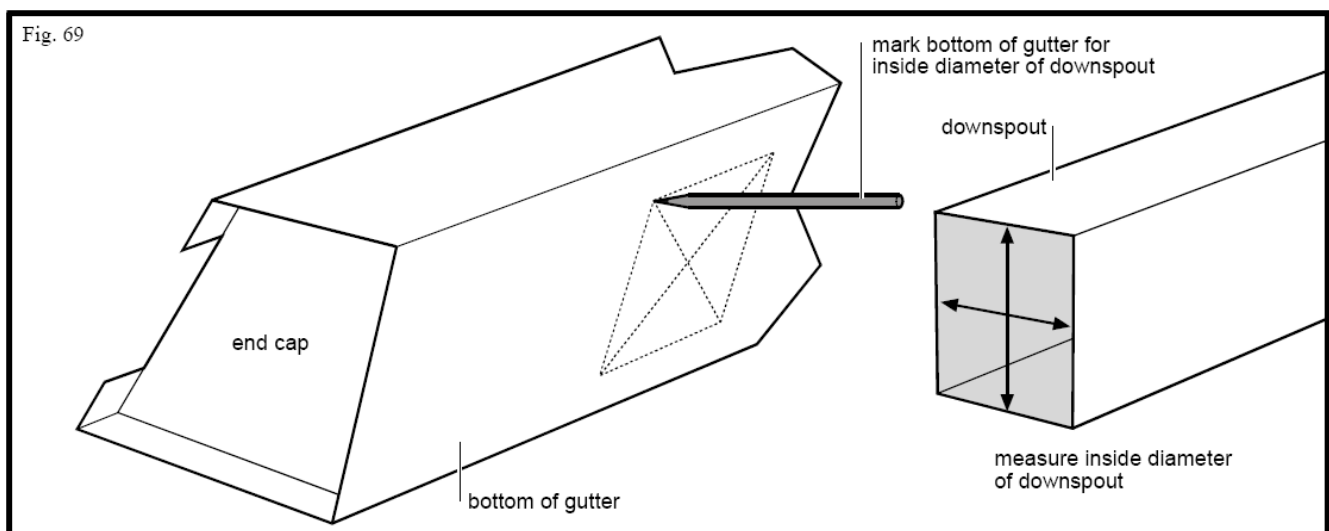

28.1.5. Using a drill, make a pilot hole, then use tin snips to cut a hole in the gutter for down spout installation.

28.1.6. To make the downspout supports, trim, square, and fold the tabs. (Figure 70)

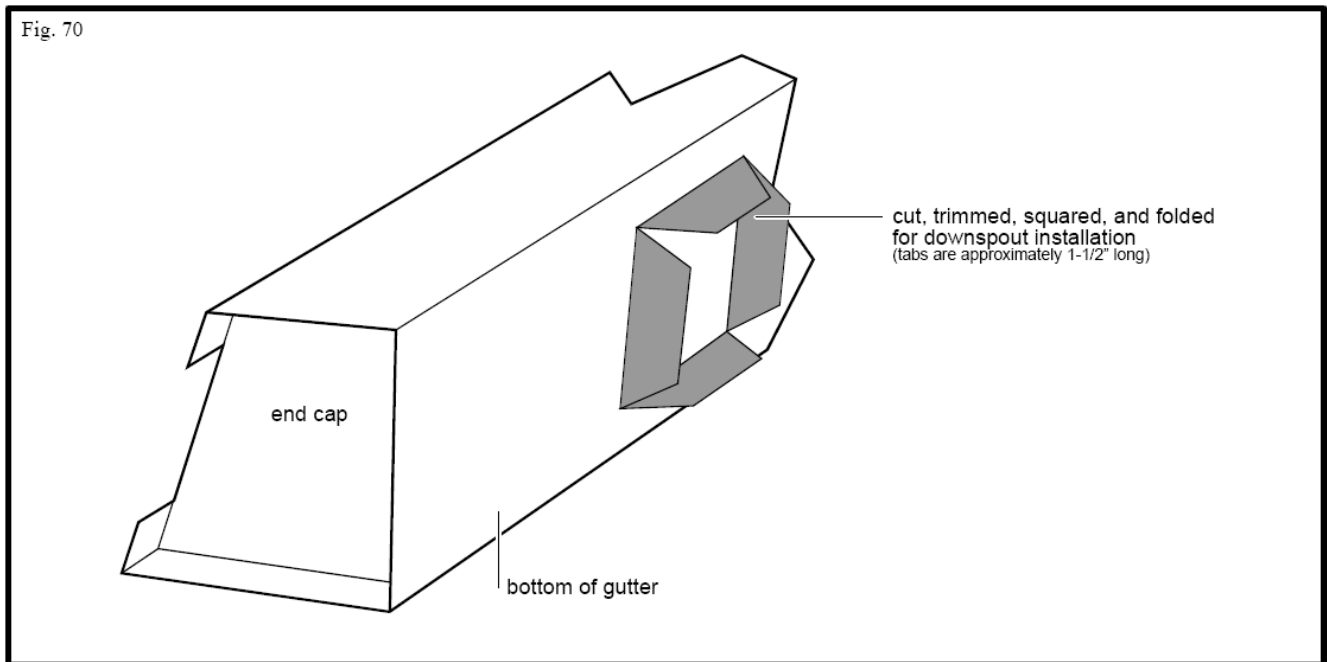

28.1.7. Seat the gutter joint against the sidewall panels, then align it to the endwall panel high rib. Using #12 x 7/8" self-tapping screws, attach the gutter to the underside of the roof panels by placing screws through the roof panel "flats" into the top of the gutter. Place screws ever 1 ft throughout the length of the gutter. The other end of the gutter will be secured as the next joint is installed. (Figure71)

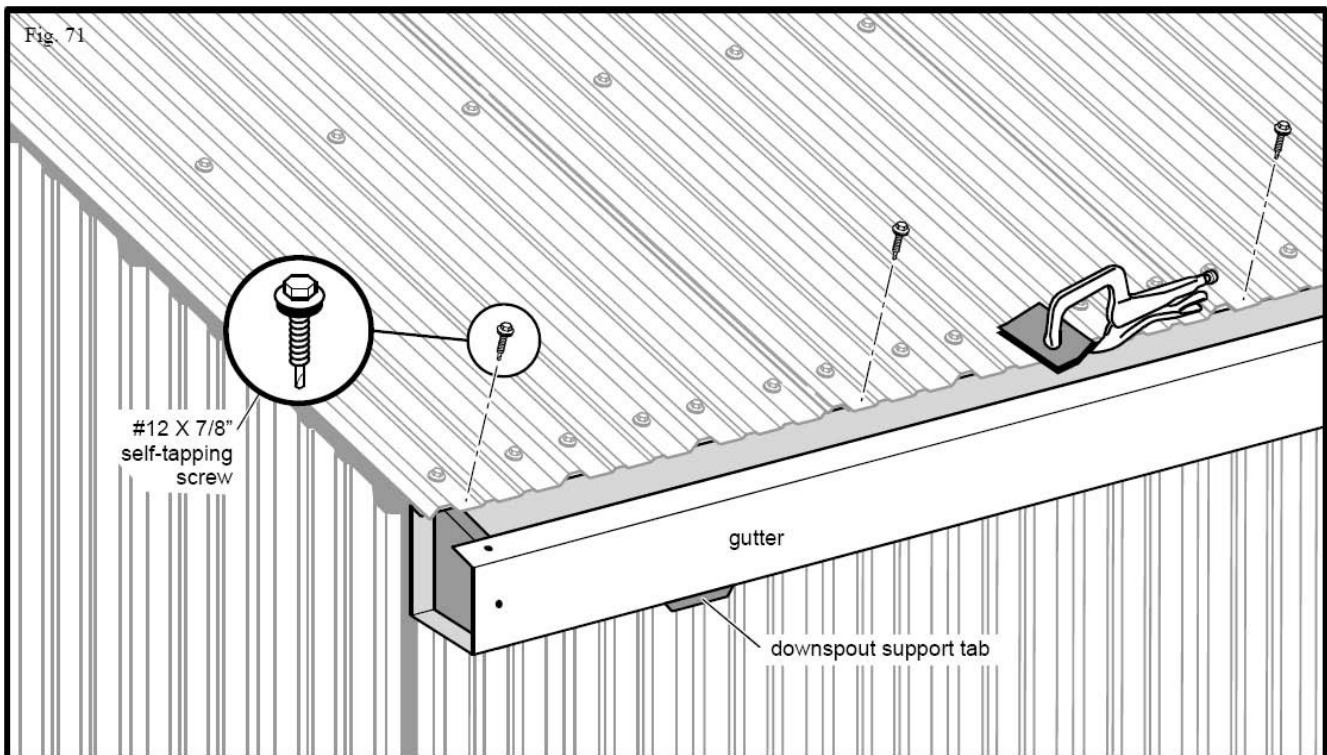

28.1.8. Place a strip of sealant tape to the bottom side of the gutter support strap.

28.1.9. Seat the gutter support strap on the high lap ribs and under the edge of the gutter.

28.1.10. Using #12 x 7/8" self-tapping screws, attach the gutter support straps to the roof panels high lap ribs and under the edge of the gutter. (Figure 72)

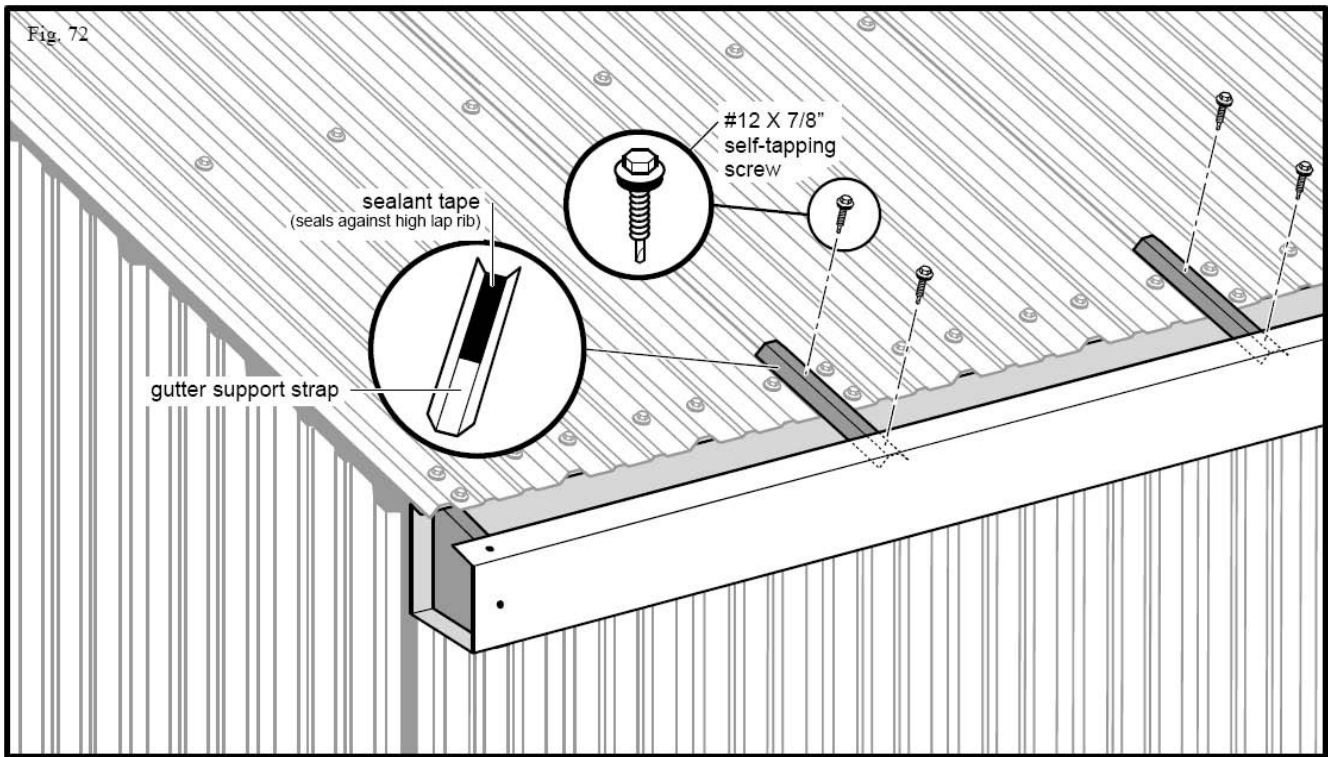

28.2. Prepare to install the remaining gutter(s). (Figure 73)

28.2.1. Overlap the joint of gutter approximately 3”.

28.2.2. Using pop rivets, secure the gutter laps as necessary.

28.2.3. Using an approved caulk, seal the gutter laps as necessary.

28.2.4. Carefully measure and cut the last joint of gutter to length. Gutter must be flush with endwall high rib while overlapping previous gutter by 3”.

28.2.5. Place and inset an end cap 1” inside the “last” joint of gutter and secure with pop rivets, then seal with caulk.

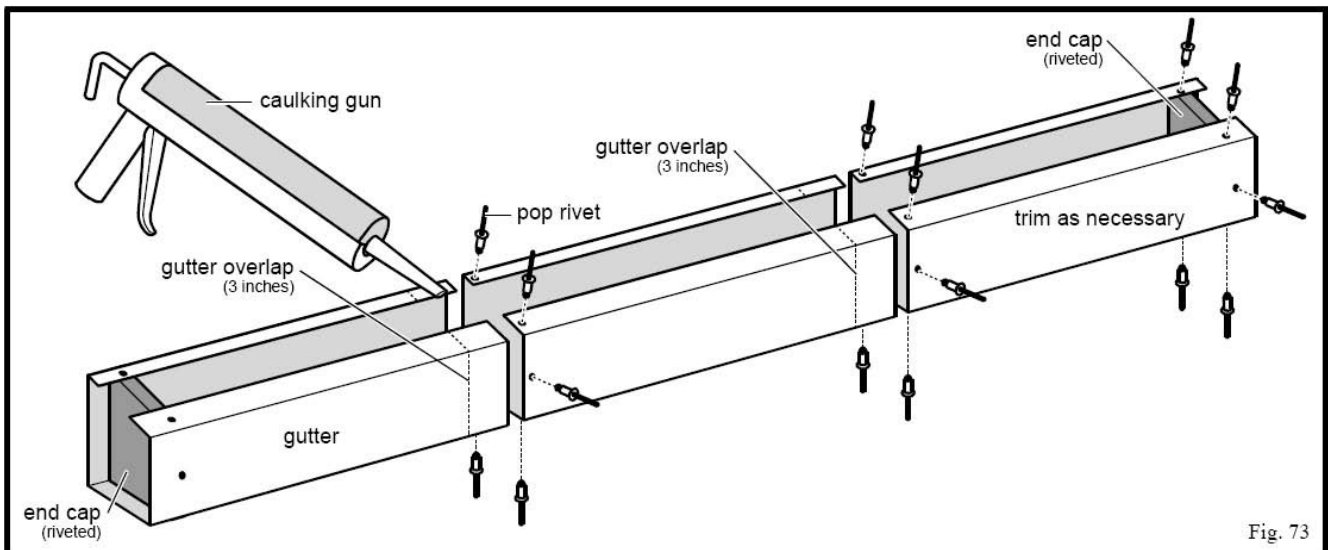
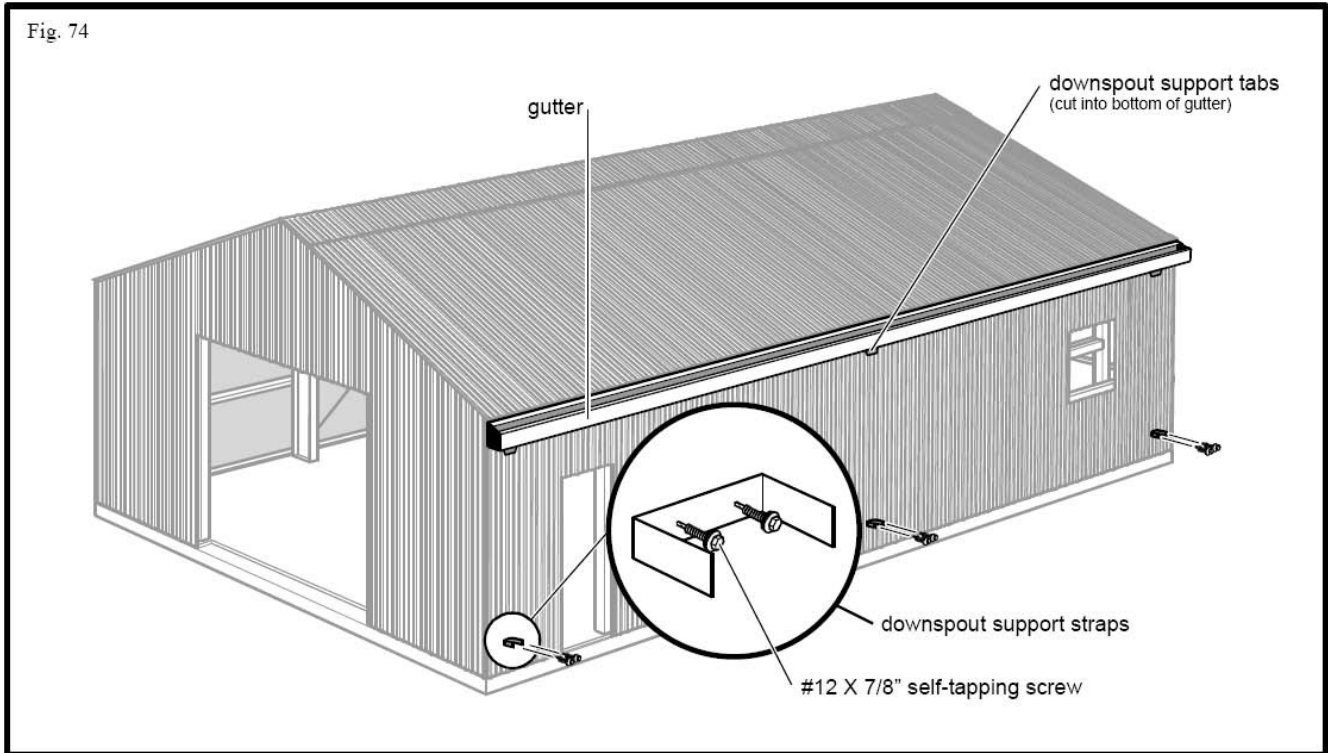

Fig. 73

28.3. Prepare the downspouts for installation. (Figure 74)

28.3.1. While aligned with the gutter downspout support tabs, use #12 x 7/8" self-tapping screws to install one downspout support strap approximately 18" above the foundation. Repeat as necessary.

28.3.2 Place-fit a downspout joint. Downspouts are typically cut to length but may be trimmed if necessary.



28.4. Secure the downspouts to the building. (Figure 75)

28.4.1. Using pop-rivets, secure the top of the downspout to the support tabs on the gutter.

28.4.2 Using #12 x 7/8" self-tapping screws, secure the bottom of the downspout to the support straps.

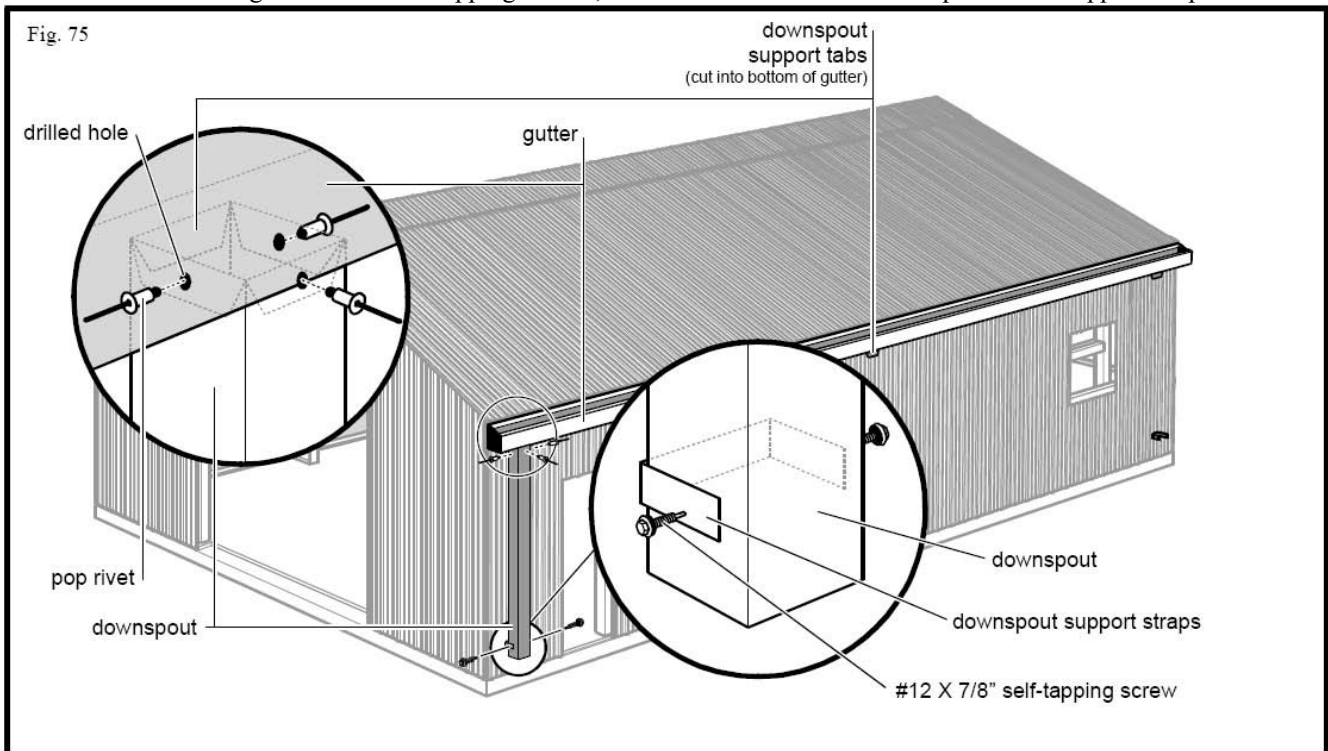

RAKE TRIM INSTALLATION

29. Prepare to install the rake trim.

Notice: Rake trim is available in several styles. A basic profile is depicted for instructional purposes. Rake trim positioning on roof panels may vary from images depicted in this manual. Apply these steps as necessary.

Safety Precaution: Use OSHA approved eye protection when operating a drill.

29.1. Prepare to install proper corner dressing; **end cap (used with eave trim)** or **corner box (used with gutter)**.

29.1.1. Using pop-rivets, secure the end cap (used with eave trim) to the rake trim. (Figure 77)

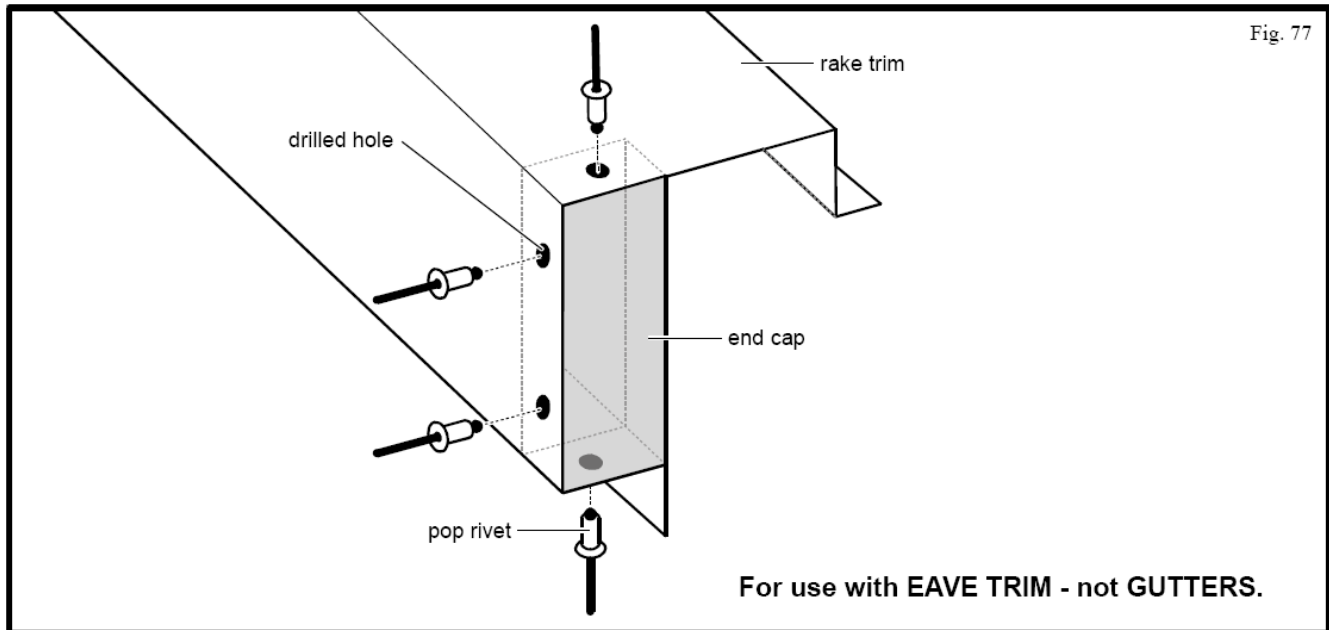

Using pop-rivets, secure the corner box (used with gutter) to the rake trim. (Figure 78)

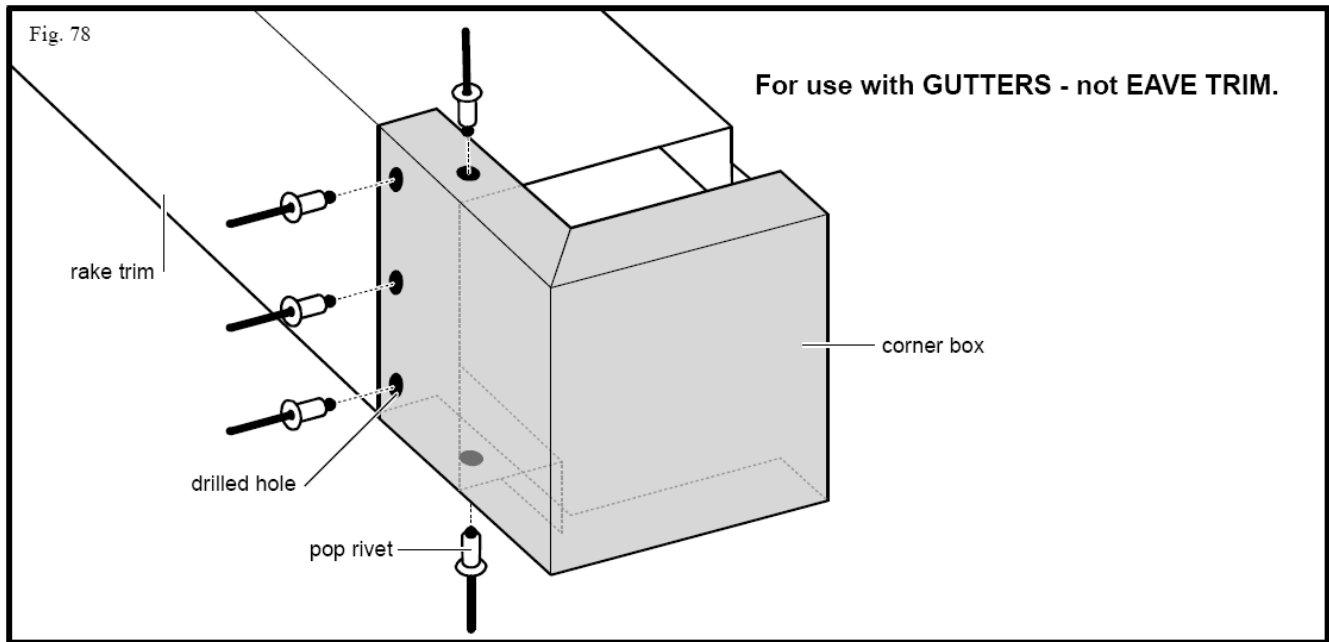

29.1. Apply sealant tape to the outer roof-side lip of the rake trim. The sealant must be continuous with no voids present. (Figure 79)

29.2.1. Leave the other strip release paper in place.

Notice: The release paper will be removed after the rake trim is attached to the sidewall.

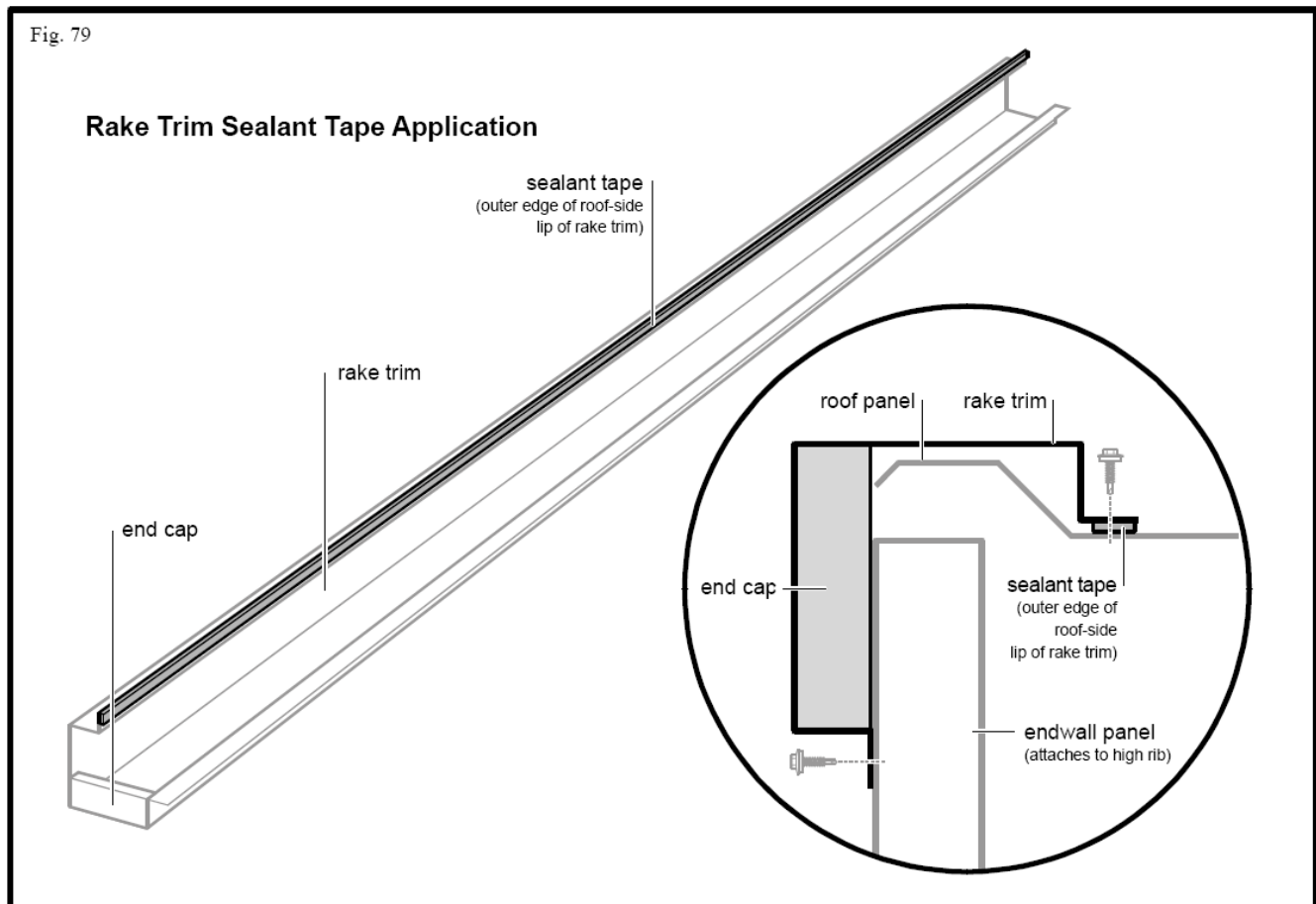

29.3. With the release paper on the sealant tape, place-fit a rake trim joint by seating it against the endwall panels while aligning it with the gutter or eave trim. (Figure 80)

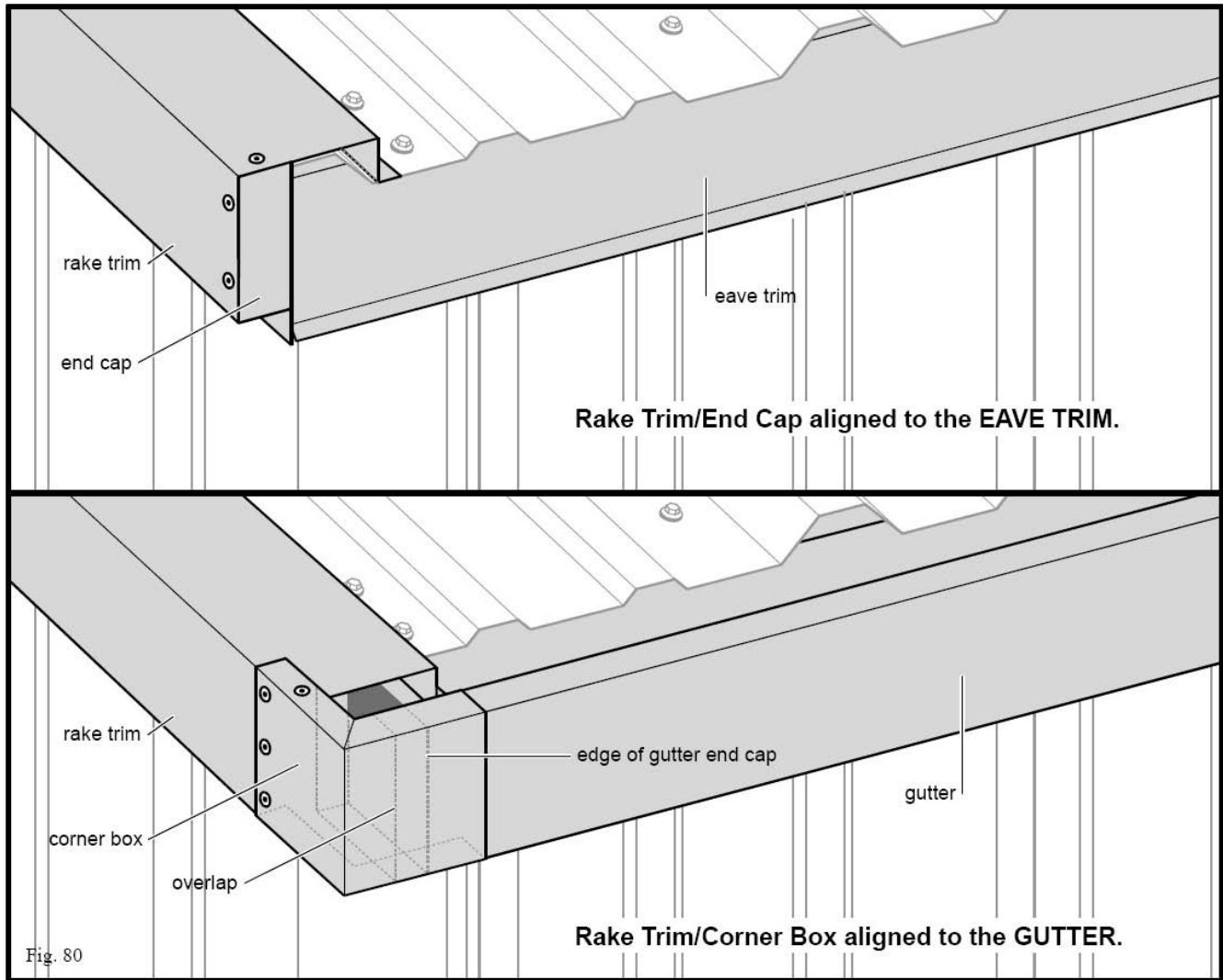

29.4. Peel the release paper from the sealant tape, the carefully align and place rake trim to the roof. To seal the rake trim to the roof, firmly press along the taped edge.

29.5. Using #12 x 7/8" self-tapping screws, secure the rake trim to the roof panels. Place the first screw 2" from the bottom then distribute them every 12" throughout the length of the rake trim. (Figure 81)

Notice: If the building requires two joints of rake trim to complete each run, do not place a screw at the high end of the first joint. It will be secured as the next joint is installed.

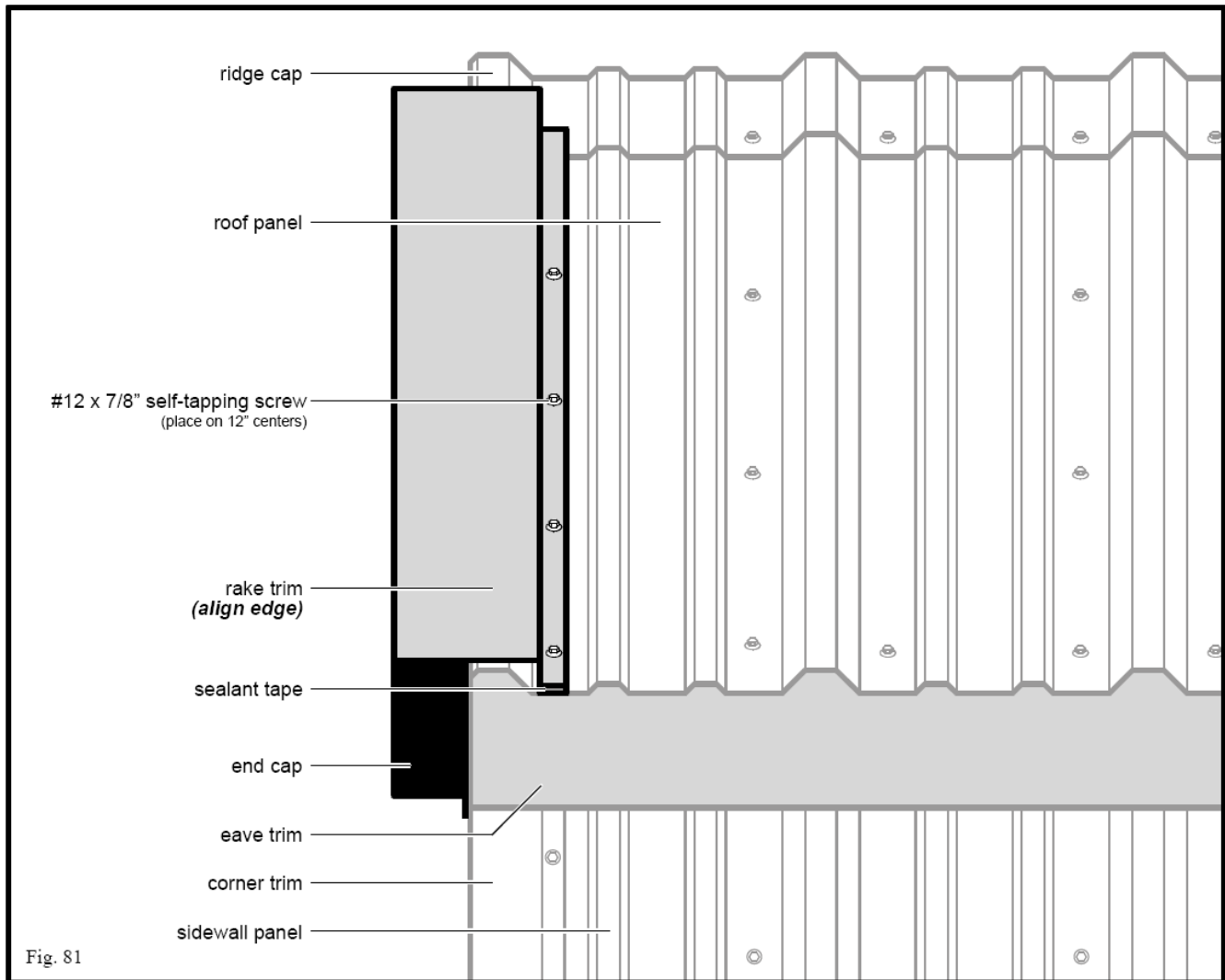

29.6. Place the outside closures under the rake trim (as specified by manufacturer) as necessary. Trim excess if necessary. As the closures are installed, use #12 x 7/8" self-tapping screws to secure the rake trim to the sidewall panels by placing screws on high ribs. (Figure 82)

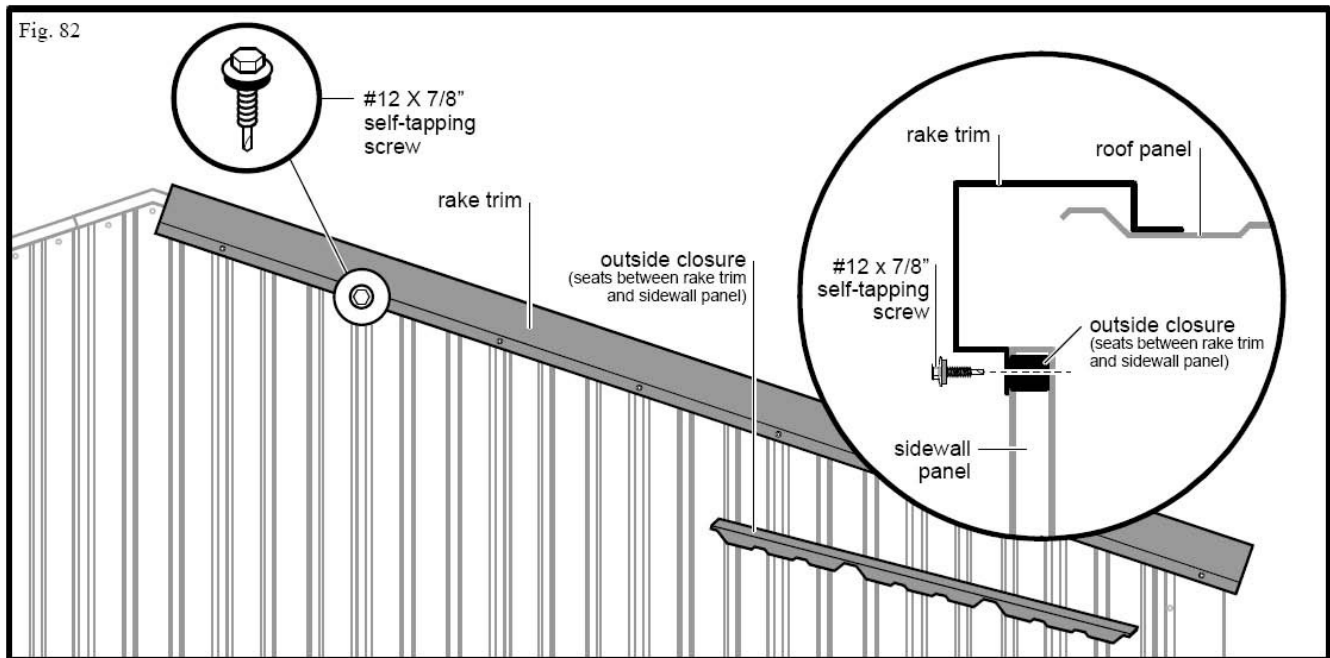

29.6.1. Repeat step 33 until all rake trim is installed.

Important: Sweep up all drill shavings from panels to avoid surface rust and damage to panel finish.

PEAK BOX INSTALLATION

30. Prepare to install the peak box. (Figure 83)

30.1. To prevent water from seeping between the peak box and roof, attach sealant tape as shown. With the release paper in place, press firmly sealant tape to insure proper adhesion. The sealant must be continuous, with no voids.

30.1.1. Ensure the peak box extends over the rake trim. Remove the release paper then carefully set the peak box into place.

30.2. To secure the peak box to the roof, place eight #12 x 7/8" self-tapping screws as shown.

30.3. Caulk the peak box at all necessary locations.

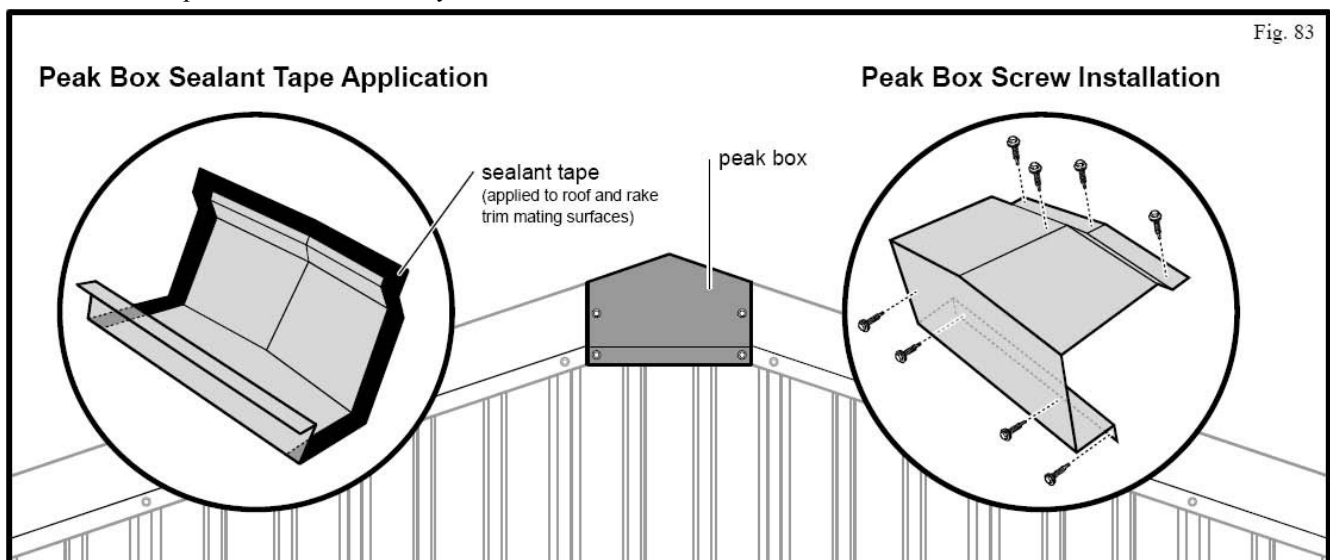

INSTALL THE SKYLIGHT PANEL CLUSTER

31. Prepare to install the Skylight Panel Cluster

Important: Skylight panel must lap over panels to the left, right, and below.

Important: The sealant tape should always be positioned to the outer edge of the panel so that water cannot seep under the panel lap. Voids will be created if screws penetrate the sealant.

31.1. Precut the insulation to accommodate the width of the roof, eave-to-eave.

Important: The insulation must be compressed between the purlins, eave struts and roof panels. Very thick or dense insulation will not compress adequately resulting in waviness in certain types of roof panels.

31.2. Install a row of insulation.

31.2.1. For details see step 30.2.

31.3. Trim the insulation for roof panel installation.

31.3.1. For details, see step 30.3.

31.4. Prepare to modify the insulation for SKYLIGHT PANEL CLUSTER installation.

31.4.1. To determine the area of insulation to be modified, place-fit the SKYLIGHT PANEL CLUSTER (Figure 84)

Notice: The skylight is positioned among standard roof panels. The group of panels must be temporarily positioned for insulation removal for the skylight.

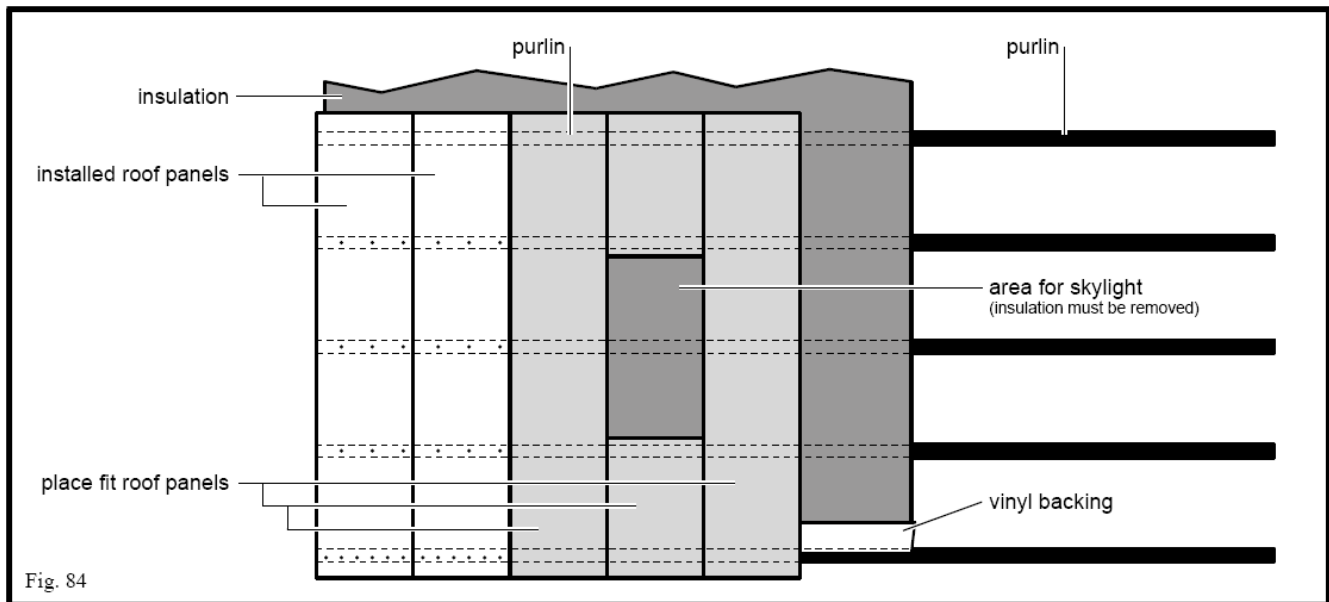

Fig. 84

31.5. Trim the insulation for SKYLIGHT PANEL CLUSTER INSTALLATION. (Figure 85)

31.5.1. Using a utility knife, without cutting through the vinyl backing, trim the “insulation” even with the surrounding (place-fit) roof panels.

31.5.2. Using a utility knife, cut an “X” from corner to corner.

31.5.3. To protect the insulation from weather, fold the flaps back as necessary. Based on the same principle as used for walk doors and windows.

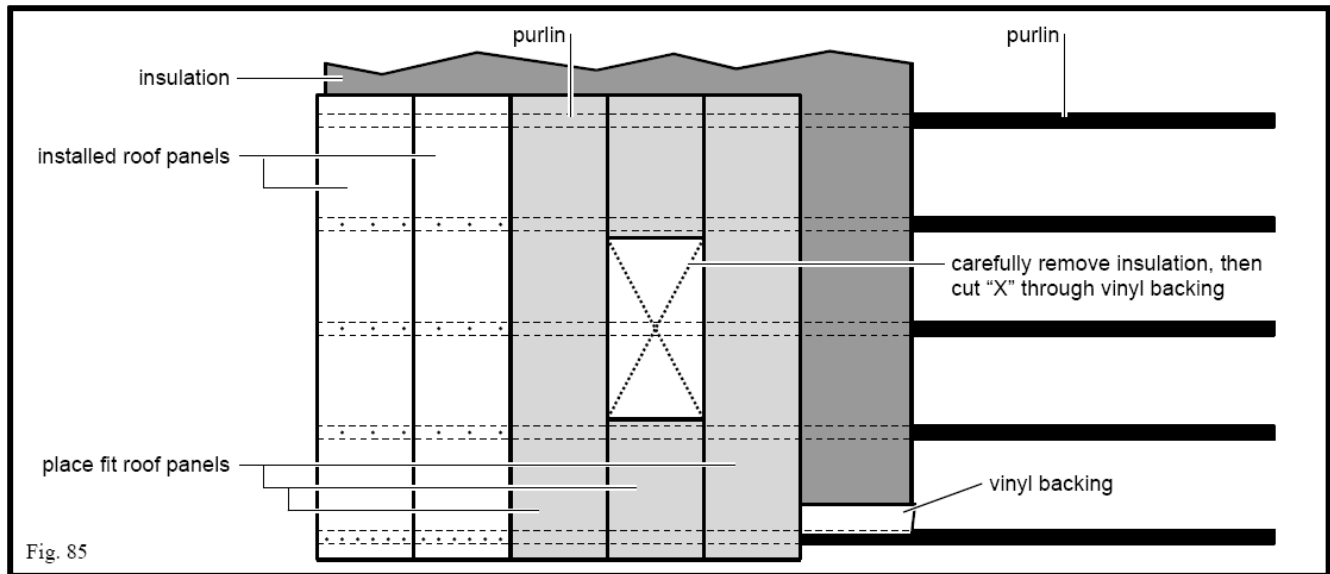

31.6. Prepare to apply sealant tape to the installed roof panel sidelap for the next panel installation. (Figure 86)

Important: So that water cannot seep into the lap, the sealant tape should always be positioned to the outer edge of the panel rib. Voids will be created in the seal if stitch screws penetrate the sealant.

31.6.1. Prior to installing sealants, use a clean rag and an approved cleaner to wipe the mating sidelap surfaces free of foreign debris and residue.

31.6.2. Apply the sidelap sealant tape to the weather side edge of the lower panel’s high lap rib (as shown). With the release paper in place, press firmly along the length of the sealant to insure proper adhesion. The sealant must be continuous, no voids can be present.

31.6.3. Be careful not to pull the sealant tape away from the panel while removing the protective paper from the sealant tape.

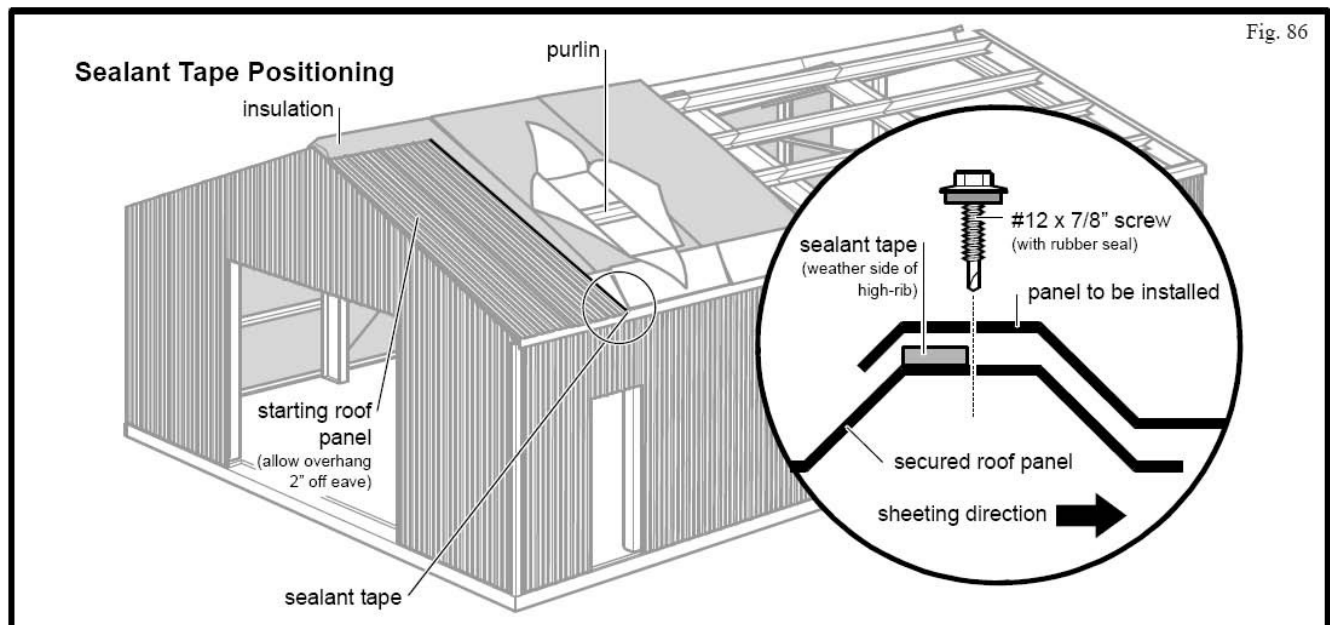

Safety Precautions: Continuously warn crews to never step on unsecured roof panels.

Safety Precaution: In case of multiple roof panel runs, do not install vice-grip clamps or fasteners on purlins where panels overlap. Completely secure one panel at a time before clamping the next panel into place.

Important: Check the Construction Drawings to determine the roof overhang at the eave.

31.7. Install the SKYLIGHT PANEL CLUSTER. (Figure 87)

31.7.1. Due to the manufacturing process, oil may be applied to help protect panels from corrosion. Prior to installation, Use a clean rag and an approved cleaner to wipe panels free of foreign debris and residue.

31.7.2. With the vinyl backing folded tightly under the panel, align and lay the panel in place sealing it approximately to the sealant tape.

31.7.3. Using vice-grip clamps or appropriate fasteners, secure both ends of the roof panel to the peak purling and eave strut.

31.7.4. Using #12 x 7/8" self-tapping screws with sealing washers, stitch the lapping ribs together on approximately 20" centers (set by the pre-drilled clearance holes)..

31.7.5. Splice an inside closure to the preceding inside closure and apply along the top of the eave trim (as specified by manufacturer), just outside of the insulation's edge.

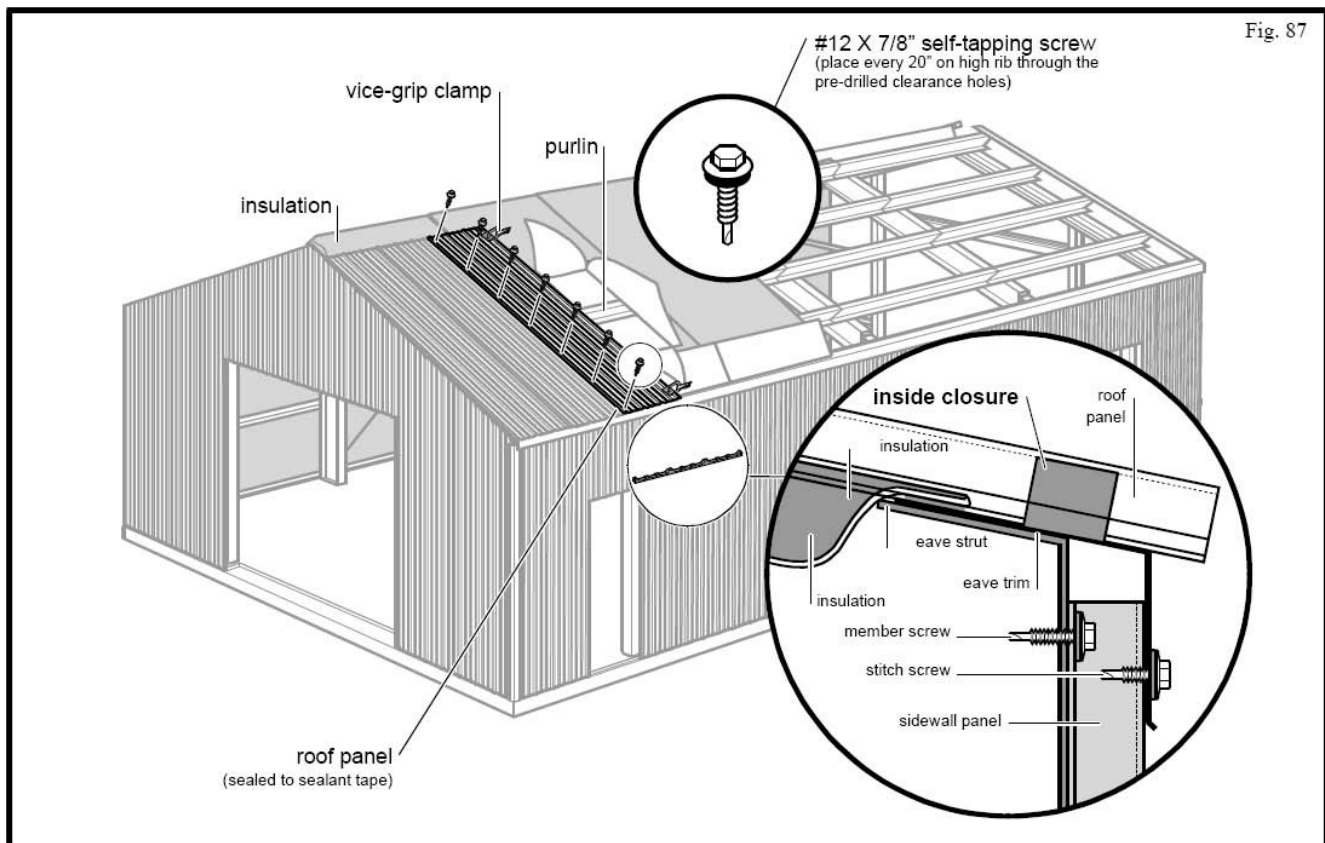

31.8. Secure the roof panel to the eave strut, purlins, and peak purlin.

31.8.1. For details, see step 30.6.

Important: For proper installation and sealing, pay close attention to the panel arrangement sequence.

31.9. Install the remaining SKYLIGHT PANEL CLUSTER AS SHOWN. (Figure 88)

31.9.1. Apply sealant tape for overlapping panels as necessary. For details, see step 30.6.3.

31.10. Continue sheeting.

Fig. 88

Single Panel Run Roofing with Sky Lights

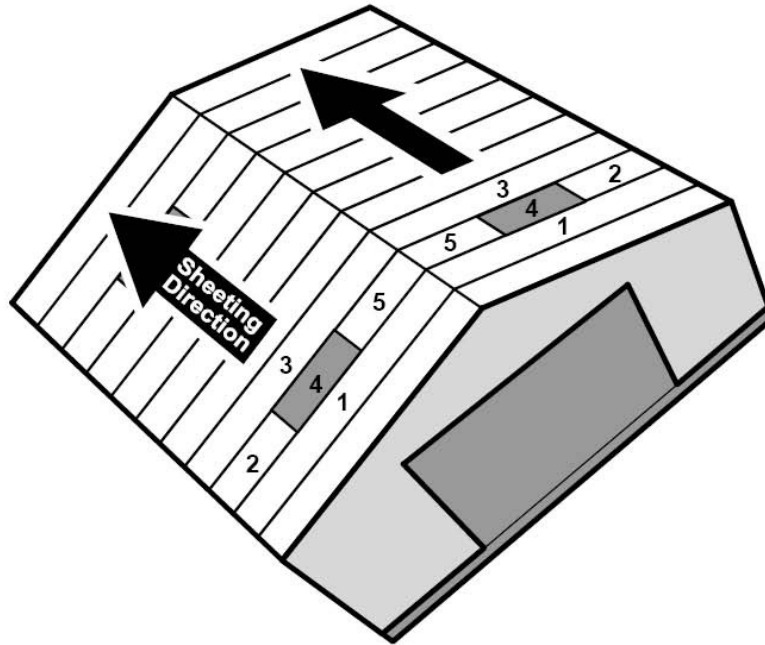

Single Panel Run Roofing with Sky Lights

