

Ground Hog Schematic

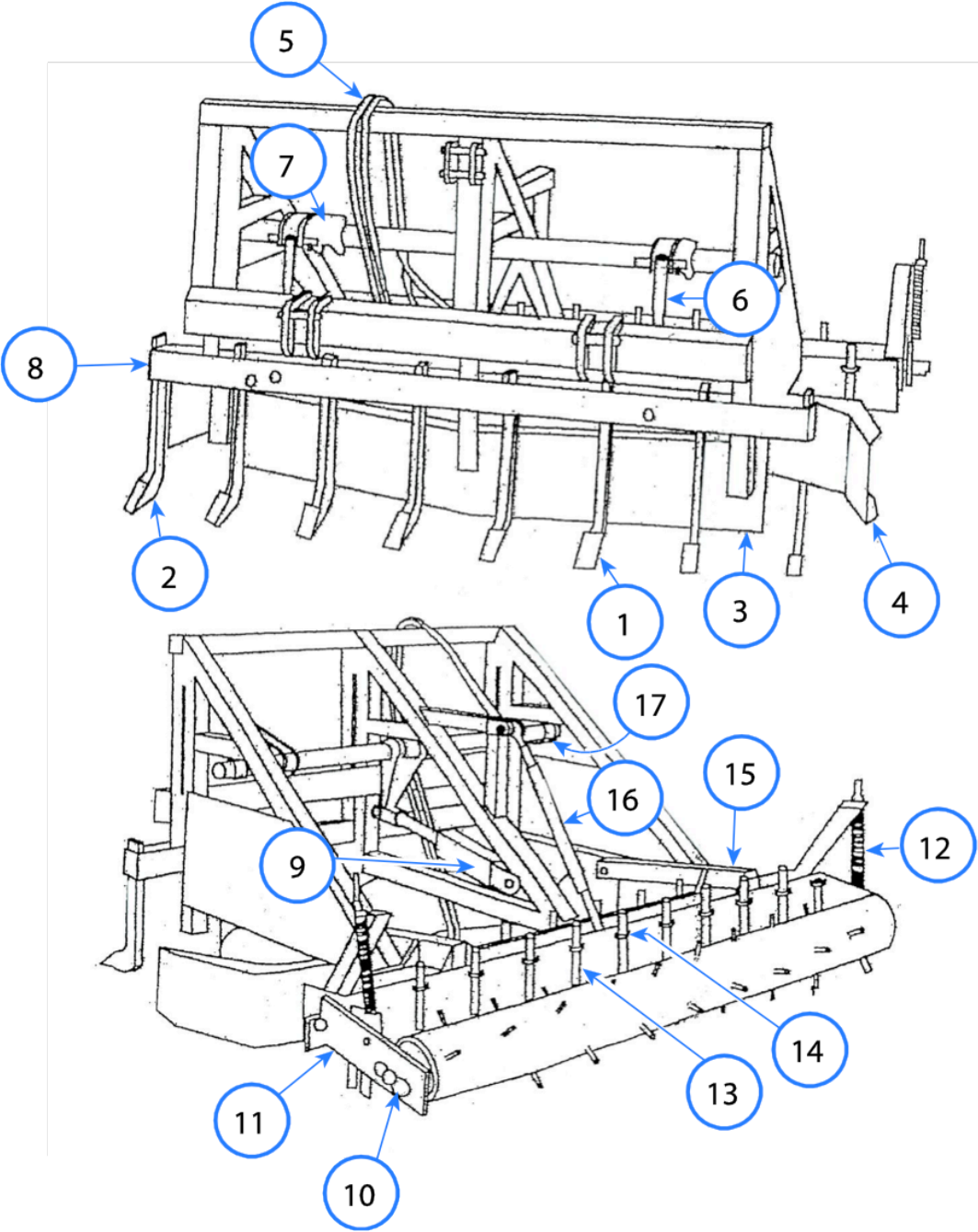



Lucas Metal Works
 396281 West 3000 Rd.
 Ochelata, OK 74051
 918-535-2726 / 866-689-8904
 LucasMetalWorks.com

PARTS LISTING & OPERATING INSTRUCTIONS

PLEASE CALL FOR PRICING

1	RIPPER POINT, HARD-SURFACED*
2	RIPPER SHANKS RIPPER SHANK W/RIPPER POINT
3	FRONT BLADE
4	BACK BLADE
5	HYDRAULIC HOSE
6	RIPPER SHANK BAR ADJUSTERS
7	RIPPER SHANK BAR LEFT ARMS
8	RIPPER SHANK BAR
9	HYDRAULIC CYLINDER
10	BEARINGS, ROLLER, 5', 6', 7', 8' MACHINE
10A	BEARINGS, ROLLER, 9' MACHINE
10B	BEARINGS, ROLLER, 10', 12' MACHINE
11	ROLLER CONNECTION PLATE 5', 6', 7', 8'
11A	ROLLER CONNECTING PLATE 9'
11B	ROLLER CONNECTING PLATE 10', 12'
12	ROLLER SPRING ASSEMBLY 5', 6', 7', 8', 9'
12A	ROLLER SPRING ASSEMBLY 10', 12'
13	I-BEAM SPIKES
14	U-BOLTS
15	I-BEAM & ROLLER SUPPORT ARMS
16	I-BEAM & ROLLER LIFT ARM
16A	I-BEAM & ROLLER RATCHET JACK
17	BUSHINGS, SHANK BAR LIFTING SHAFT

OPERATING INSTRUCTIONS:

FOR PROPER GRADING, ADJUST THE TOP-LINK ON THE TRACTOR TO ALLOW THE BACK BLADE (#4) TO BE 1.5" LOWER THAN THE FRONT BLADE (#3) WHEN THE MACHINE IS SUSPENDED APPROXIMATELY 6" ABOVE THE GROUND.

WHEN WORKING THE ARENA, THE I-BEAM/ROLLER SUPPORT ARMS (#15) SHOULD BE RESTING ON THE BACK BLADE (#4).

NOTE: PARTS 10, 10A, 10B & 17 **SHOULD BE GREASED EVERY 10 HOURS OF USE.**

CAUTION: DO NOT OPERATE MACHINE WITHOUT RIPPER POINTS ON SHANKS.

* HARD SURFACING ON RIPPER POINTS "APPROXIMATELY" DOUBLES THE RIPPER POINT LIFE.